



*DVB INTERACTION CHANNEL FOR CABLE TV  
DISTRIBUTION SYSTEM (CATV)*

*DVB DOCUMENT A023*  
February 1997

***Reproduction of the document in whole or in part without prior permission of the DVB  
Project Office is forbidden.***

DVB Project Office  
28<sup>th</sup> February 1997

## TABLE OF CONTENTS

|  |          |
|--|----------|
| <b>1 Scope</b>   | <b>4</b> |
| <b>2 Normative references</b>  | <b>4</b> |
| <b>3 Abbreviations</b>   |          |
| <b>4 Reference model for system architecture of narrowband interaction channels in a broadcasting scenario (Asymmetric interactive services)</b> | <b>5</b> |
| 4.1 Protocol Stack Model   |          |
| 4.2 System Model   |          |
| <b>5 DVB Interaction Channel specification for CATV networks</b>   | <b>9</b> |
| 5.1 System Concept   | 9        |
| 5.1.1 Out-of-band / In-band principle  | 9        |
| 5.1.2 Spectrum allocation  | 9        |
| 5.1.3 FDM/TDMA Multiple Access   | 10       |
| 5.1.4 Bit rates and Framing  | 11       |
| 5.2 Lower Physical Layer Specification   | 11       |
| 5.2.1 Forward Interaction Path (Downstream OOB)  | 13       |
| 5.2.1.1 Frequency Range (Downstream OOB)   | 13       |
| 5.2.1.2 Modulation and Mapping (Downstream OOB)  | 13       |
| 5.2.1.3 Shaping filter (Downstream OOB)  | 14       |
| 5.2.1.4 Randomiser (Downstream OOB)  | 15       |
| 5.2.1.5 Bit rate (Downstream OOB)  | 16       |
| 5.2.1.6 Receiver power level (Downstream OOB)  | 16       |
| 5.2.1.7 Summary (Downstream OOB)   | 17       |
| 5.2.1.8 Bit error rate downstream OOB (Informative)  | 19       |
| 5.2.2 Forward Interaction Path (Downstream IB)   | 19       |
| 5.2.3 Return Interaction Path (Upstream)   | 19       |
| 5.2.3.1 Frequency range (Upstream)   | 19       |
| 5.2.3.2 Modulation and Mapping (Upstream)  | 19       |
| 5.2.3.3 Shaping filter (Upstream)  | 20       |
| 5.2.3.4 Randomiser (Upstream)  | 21       |
| 5.2.3.5 Bit rate (Upstream)  | 21       |
| 5.2.3.6 Transmit power level (Upstream)  | 22       |
| 5.2.3.7 Carrier suppression when idle (Upstream)   | 22       |
| 5.2.3.8 Summary (Upstream)   | 23       |
| 5.2.3.9 Packet loss upstream (Informative)   | 26       |
| 5.3 Framing  | 26       |
| 5.3.1 Forward Interaction Path (Downstream OOB)  | 26       |
| 5.3.1.1 Signaling Link Extended Superframe Framing Format  | 26       |
| 5.3.1.2 Frame overhead   | 27       |
| 5.3.1.3 Payload structure  | 28       |
| 5.3.2 Forward Interaction Path (Downstream IB)   | 33       |
| 5.3.3 Return Interaction Path (Upstream)   | 35       |
| 5.3.3.1 Slot Format  | 35       |
| 5.4 Slot timing assignment   | 37       |
| 5.4.1 Downstream slot position reference (Downstream OOB)  | 37       |
| 5.4.2 Downstream slot position reference (Downstream IB)   | 37       |

|  |    |
|--|----|
| 5.4.3 Upstream slot positions  | 39 |
| 5.4.2.1 Rate 256 kbit/s  | 40 |
| 5.4.2.2 Rate 1,544 Mbit/s  | 40 |
| 5.4.2.3 Rate 3,088 Mbit/s  | 41 |
| 5.4.4 Slot position counter  | 42 |
| 5.5 <i>MAC Functionality</i>   | 43 |
| 5.5.1 MAC Reference Model  | 43 |
| 5.5.2 MAC Concept  | 44 |
| 5.5.2.1 Relationship between higher layers and MAC protocol  | 44 |
| 5.5.2.2 Relationship between physical layer and MAC protocol   | 45 |
| 5.5.2.3 Relationship between physical layer slot position counter and MAC slot assignment              | 45 |
| 5.5.2.4 Access modes (Contention / Ranging / Fixed rate / Reservation)                                 | 46 |
| 5.5.2.5 MAC Error Handling Procedures  | 47 |
| 5.5.2.5 MAC messages   | 47 |
| 5.5.3 MAC Initialization and Provisioning  | 50 |
| 5.5.3.1 <MAC> Provisioning Channel Message (Broadcast Downstream)                                      | 51 |
| 5.5.3.2 <MAC> Default Configuration Message (Broadcast Downstream)                                     | 52 |
| 5.5.4 Sign On and Calibration  | 53 |
| 5.5.4.1 <MAC> Sign-On Request Message (Broadcast Downstream)   | 56 |
| 5.5.4.2 <MAC> Sign-On Response Message (Upstream Contention Ranging)                                   | 57 |
| 5.5.4.3 <MAC> Range and Power Calibration Message (Singlecast Downstream)                              | 57 |
| 5.5.4.4 <MAC> Ranging and Power Calibration Response Message (Upstream reserved or contention Ranging) | 58 |
| 5.5.4.5 <MAC> Initialization Complete Message (Singlecast Downstream)                                  | 58 |
| 5.5.5 Default Connection Establishment   | 58 |
| 5.5.5.1 <MAC> Connect Message (Singlecast Downstream)  | 60 |
| 5.5.5.2 <MAC> Connect Response (Upstream contention, reserved or fixed rate access)                    | 64 |
| 5.5.5.3 <MAC> Connect Confirm (Singlecast Downstream)  | 65 |
| 5.5.6 Data connections   | 65 |
| 5.5.6.1 Fixed Rate Access  | 66 |
| 5.5.6.2 Contention Based Access  | 66 |
| 5.5.6.3 Reservation Access   | 66 |
| 5.5.7 MAC Link Management  | 70 |
| 5.5.7.1 Power and Timing Management  | 70 |
| 5.5.7.2 TDMA Allocation Management   | 71 |
| 5.5.7.3 Channel Error Management   | 74 |
| 5.5.7.4 Link Management Messages   | 74 |

## 1 Scope

This European Telecommunication Standard (ETS) is the baseline specification for the provision of interaction channel for CATV networks.

It is not intended to specify a return channel solution associated to each broadcast system because the inter-operability of different delivery media to transport the return channel is desirable.

The solutions provided in this ETS for interaction channel for CATV networks are a part of a wider set of alternatives to implement interactive services for Digital Video Broadcasting (DVB) systems.

## 2 Normative references

This ETS incorporates by dated and undated reference, provisions from other publications. These normative references are cited at the appropriate places in the text and the publications are listed hereafter. For dated references, subsequent amendments to or revisions of any of these publications apply to this ETS only when incorporated in it by amendment or revision. For undated references the latest edition of the publication referred to applies.

- [1] ITU-T Recommendations: "V.21, V.22, V.22bis, V.23, V.25, V.32, V.32bis, V.34 and V.42".
- [2] 91/263/EEC Directive on Terminal equipment
- [3] "Interfaces for DVB-IRD (DVB-PI-123/TM1326 Rev 2) 18th April 1995".
- [4] prETS 300 802: "DVB specification - Network Independent Protocols for interactive Services (in preparation - Draft B 16th January 1996)".
- [5] EN 50083 "Cabled Distribution Systems".
- [6] ETS 300 429: "Digital Broadcasting systems for television, sound and data services; Framing structure, channel coding and modulation for cable systems (DVB-C spec)".
- [7] ETS 300 421: "Digital Broadcasting systems for television, sound and data services; Framing structure, channel coding and modulation for 11/12 satellite services. (DVB-S spec)".
- [8] ITU Recommendation I.361
- [9] ITU-T Recommendation I.363

## 3 Abbreviations

For the purposes of this ETS, the following abbreviations apply:

|       |  |
|-------|--|
| BC    | Broadcast Channel                        |
| BRA   | Basic Rate Access                        |
| CATV  | CABLE TV distribution system             |
| DAVIC | Digital Audiovisual Council              |
| DCE   | Data Communication Equipment             |
| DTE   | Data Termination Equipment               |
| DTMF  | Dual Tone Multifrequency (dialling mode) |
| DVB   | Digital Video Broadcasting               |
| GSTN  | General Switched Telephone Network       |
| IB    | In-Band                                  |
| IC    | Interaction Channel                      |
| INA   | Interactive Network Adapter              |
| IRD   | Integrated Receiver Decoder              |
| ISDN  | Integrated Services Digital Network      |

|       |   |
|-------|---|
| IQ    | In-phase and Quadrature Components        |
| LSB   | Least Significant Bit                     |
| MAC   | Media Access Control                      |
| MMDS  | Microwave Multi-point Distribution System |
| NIU   | Network Interface Unit                    |
| NSAP  |   |
| OOB   | Out of Band                               |
| OSI   | Open Systems Interconnection              |
| PM    | Pulse Modulation                          |
| PSTN  | Public Switched Telephone Network         |
| QAM   | Quadrature Amplitude Modulation           |
| QoS   | Quality of Service                        |
| QPSK  | Quaternary Phase Shift Keying             |
| SMATV | Satellite Master Antenna Television       |
| STB   | Set Top Box                               |
| STU   | Set Top Unit                              |
| TDMA  | Time Division Multiplex Access            |
| TS    | Transport Stream                          |

## 4 Reference model for system architecture of narrowband interaction channels in a broadcasting scenario (Asymmetric interactive services)

### 4.1 Protocol Stack Model

For asymmetric interactive services supporting broadcast to the home with narrowband return channel, a simple communications model consists of the following layers:

**physical layer:** Where all the physical (electrical) transmission parameters are defined.

**transport layer:** Defines all the relevant data structures and communication protocols like data containers, etc.

**application layer:** Is the interactive application software and runtime environments (e.g. home shopping application, script interpreter, etc.).

This ETS addresses the lower two layers (the physical and transport) leaving the application layer open to competitive market forces. It is not the role of the DVB to define a standardized

A simplified model of the OSI layers was adopted to facilitate the production of specifications for these nodes. Figure 1 points out the lower layers of the simplified model and identifies some of the key parameters for the lower two layers. Following the user requirements for interactive services, no attempt will be made to consider higher layers in this ETS.

## Layer Structure for Generic System Reference Model

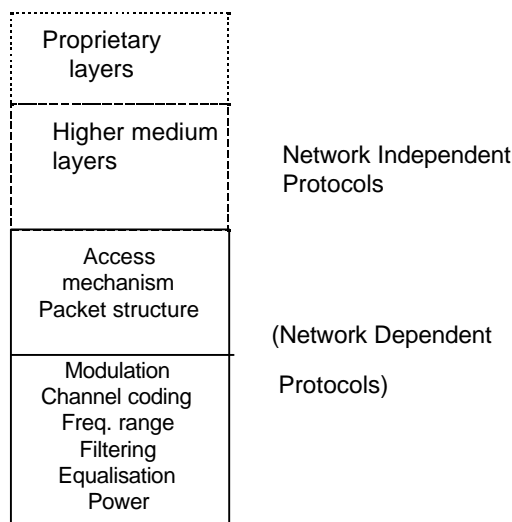

**Figure 1: Layer structure for generic system reference model**

This specification addresses the PSTN/ISDN network specific aspects only. The network independent protocols will be specified separately [9].

### 4.2 System Model

Figure 2 shows the system model which is to be used within DVB for interactive services.

In the system model, two channels are established between the Service provider and the User:

- **Broadcast channel (BC)**: A unidirectional broadband Broadcast Channel including video, audio and data. BC is established from the service provider to the users. It may include the Forward Interaction path.
- **Interaction channel (IC)**: A Bi-directional Interaction Channel is established between the service provider and the user for interaction purposes. It is formed by:
  - **Return Interaction path (Return Channel)**: From the User to the Service Provider. It is used to make requests to the service provider or to answer questions. It is a narrowband channel. Also commonly known as return channel.
  - **Forward Interaction path**: From the service provider to the user. It is used to provide some sort of information by the service provider to the user and any other required communication for the interactive service provision. It may be embedded into the broadcast channel. It is possible that this channel is not required in some simple implementations which make use of the Broadcast Channel for the carriage of data to the user.

The user terminal is formed by the Network Interface Unit (NIU) (consisting of the Broadcast Interface Module (BIM) and the Interactive Interface Module (IIM)) and the Set Top Unit (STU). The user terminal provides interface for both broadcast and interaction channels. The interface between the user terminal and the interaction network is via the Interactive Interface Module.

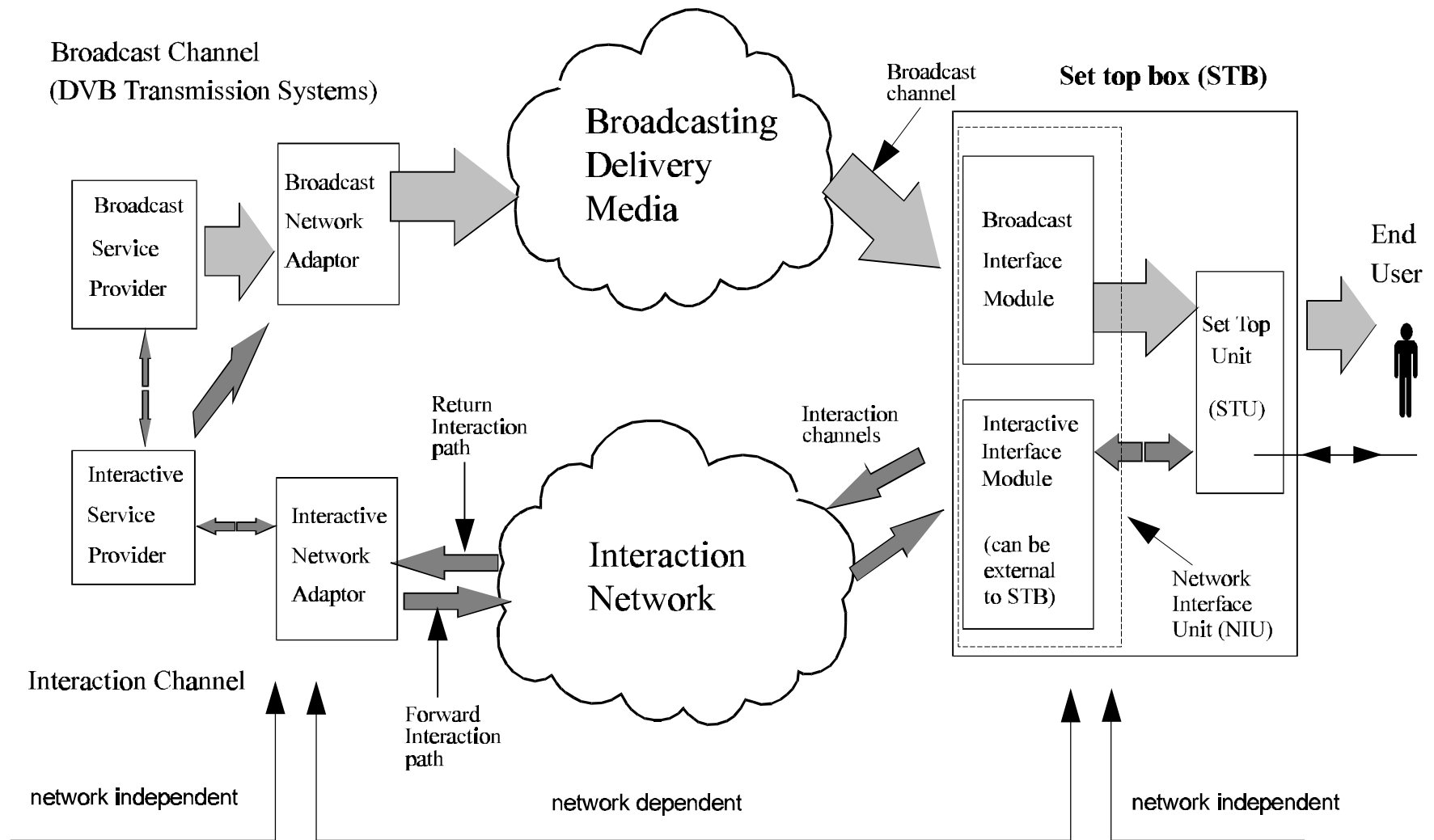

Figure 2: A generic system Reference Model for Interactive Systems

## 5 DVB Interaction Channel specification for CATV networks

The CATV infrastructures can support the implementation of the Return Channel for interactive services suitable for DVB broadcasting systems.

CATV can be used to implement interactive services in the DVB environment, providing a bi-directional communication path between the user terminal and the service provider.

### 5.1 System Concept

The interactive system is composed of Forward Interaction path (downstream) and Return Interaction path (upstream). The general concept is to use downstream transmission from the INA to the NIUs to provide synchronisation and information to all NIUs. This allows the NIUs to adapt to the network and send synchronised information upstream.

Upstream transmission is divided into time slots which can be used by different users, using the technique of Time Division Multiple Access (TDMA). One downstream channel is used to synchronise up to 8 upstream channels, which are all divided into time slots. A counter at the INA is sent periodically to the NIUs, so that all NIUs work with the same clock. This gives the opportunity to the INA to assign time slots to different users.

Three major access modes are provided with this system. The first one is based on contention access, which lets users send information at any time with the risk to have a collision with other user's transmissions. The second and third modes are contention-less based, where the INA either provides a finite amount of slots to a specific NIU, or a given bit rate requested by a NIU until the INA stops the connection on NIU's demand. These access modes are dynamically shared among time slots, which allows NIUs to know when contention based transmission is or is not allowed. This is to avoid a collision for the two contention-less based access modes.

Periodically, the INA will indicate to new users that they have the possibility to go through sign-on procedure, in order to give them the opportunity to synchronise their clock to the network clock, without risking collisions with already active users. This is done by leaving a larger time interval for new users to send their information, taking into account the propagation time required from the INA to the NIUs and back.

#### 5.1.1 Out-of-band / In-band principle

This interactive system is based either on out of band (OOB) or in-band (IB) downstream signalling. However, Set Top Boxes do not need to support both systems.

In the case of OOB signalling, a Forward Interaction path is added. This path is reserved for interactivity data and control information only. The presence of this added Forward Information path is in that case mandatory. However, it is also possible to send higher bit rate downstream information through a DVB-C channel whose frequency is indicated in the forward information path.

In the case of IB signalling, the Forward Information path is embedded into the MPEG-2 TS of a DVB-C channel. Note that it is not mandatory to include the Forward Information path in all DVB-C channels.

Both systems can provide the same quality of service. However, the overall system architecture will differ between networks using IB set top boxes and OOB set top boxes. Note also that both types of systems may exist on the same networks under the condition that different frequencies are used for each system.

#### 5.1.2 Spectrum allocation

The figure 3 indicates a possible spectrum allocation. Although not mandatory, a guideline is provided to use the following preferred frequency ranges, 70-130 MHz and/or 300-862 MHz for the Forward Interaction path (downstream OOB) and 5-65 MHz for the Return Interaction path (upstream), or parts thereof. To avoid filtering problems in the bidirectional video amplifiers and in the Set Top Boxes, the upper limit 65 MHz for the upstream flow shall not be used together with the lower limit 70 MHz for the downstream flow in the same system.



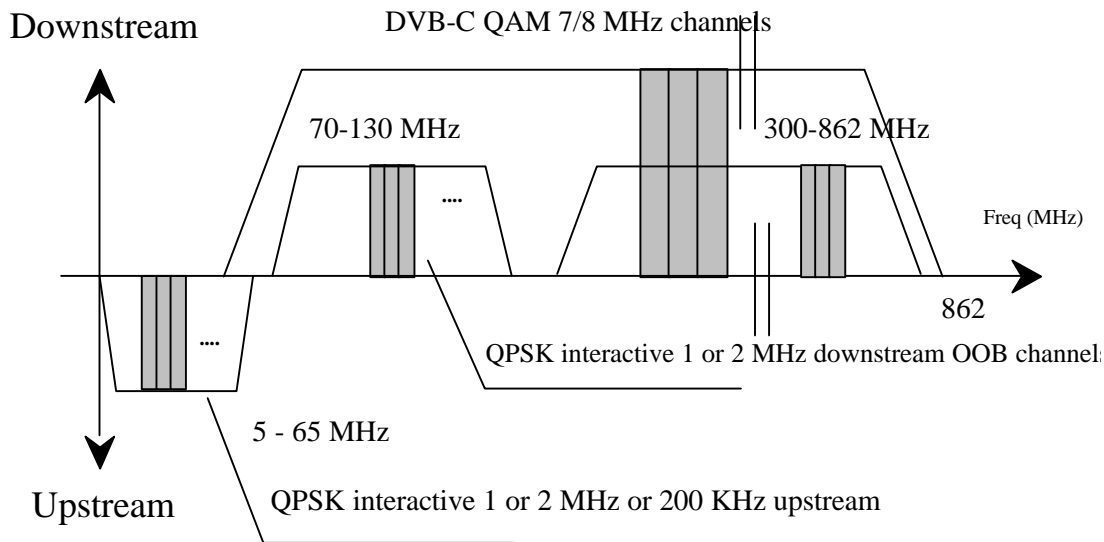

**Figure 3: DVB preferred frequency ranges for CATV interactive systems**

### 5.1.3 FDM/TDMA Multiple Access

A multiple access scheme is defined in order to have different users share the same transmission media. Downstream information is sent broadcast to all users of the networks. Thus, an address assignment exists for each user which allows the INA to send information singlecast to one particular user. Two addresses are stored in set top boxes in order to identify users on the network:

**MAC address :** It is a 48-bit value representing the unique MAC address of the NIU. This MAC address may be hard coded in the NIU or be provided by external source.

**NSAP address :** It is a 160-bit value representing a network address. This address is provided by higher layers during communication.

Upstream information may come from any user in the network and must therefore also be differentiated at the INA using the set of addresses defined above.

Upstream and OOB downstream channels are divided into separate channels of 1 or 2 MHz bandwidth for downstream and 1 or 2 MHz or 200 kHz for upstream. Each downstream channel contains a synchronisation frame used by up to 8 different upstream channels, whose frequencies are indicated by the Media Access Control (MAC) protocol.

Within upstream channels, users send packets with TDMA type access. This means that each channel is shared by many different users, who can either send packets with a possibility of collisions when this is allowed by the INA, or request transmission and use the packets assigned by the INA to each user specifically. Assuming each channel can therefore accommodate thousands of users at the same time, the upstream bandwidth can easily be used by all users present on the network at the same time.

The TDMA technique utilises a slotting methodology which allows the transmit start times to be synchronised to a common clock source. Synchronising the start times increases message throughput of this signalling channel since the message packets do not overlap during transmission. The period between sequential start times are identified as slots. Each slot is a point in time when a message packet can be transmitted over the signalling link.

The time reference for slot location is received via the downstream channels generated at the Delivery System and received simultaneously by all set-top units. Note that this time reference is not sent in the same way for OOB and IB signalling. Since all NIU's reference the same time base, the slot times are

aligned for all NIU's. However, since there is propagation delay in any transmission network, a time base ranging method accommodates deviation of transmission due to propagation delay.

Since the TDMA signalling link is used by NIUs that are engaged in interactive sessions, the number of available message slots on this channel is dependent on the number of simultaneous users. When messaging slots are not in use, an NIU may be assigned multiple message slots for increased messaging throughput. Additional slot assignments are provided to the NIU from the downstream signalling information flow.

There are different access modes for the upstream slots :

- reserved slots with fixed rate reservation (Fixed rate Access: the user has a reservation of one or several timeslots in each frame enabling, e.g. for voice, audio)
- reserved slots with dynamic reservation (Reservation Access: the user sends control information announcing his demand for transmission capacity. He gets grants for the use of slots)
- contention based slots (these slots are accessible for every user. Collision is possible and solved by a contention resolution protocol )
- ranging slots (these slots are used upstream to measure and adjust the time delay and the power).

These slots may be mixed on a single carrier to enable different services on one carrier only. If one carrier is assigned to one specific service, only those slot types will be used which are needed for this service. Therefore a terminal can be simplified to respond to only those slot types assigned to the service.

#### **5.1.4 Bit rates and Framing**

For the interactive downstream OOB channel, a rate of 1,544 Mbit/s or 3,088 Mbit/s may be used. For downstream IB channels, no other constraints than those specified in the DVB-C specifications exist, but a guideline would be to use rates multiples of 8 kbit/s.

Downstream OOB channels continuously transmit a frame based on T1 type framing, in which some information is provided for synchronisation of upstream slots. Downstream IB channels transmit some MPEG-2 TS packets with a specific PID for synchronisation of upstream slots (at least one packet containing synchronization information must be sent in every period of 3ms).

For upstream transmission, the INA can indicate three types of transmission rates to users, specifically 3,088 Mbit/s, 1,544 Mbit/s or 256 kbit/s. The INA is responsible of indicating which rate may be used by NIUs. It would imply all NIUs to be able to either transmit with 256 kbit/s, 1,544 Mbit/s, or 3,088 Mbit/s. Only the implementation of one of these bit rates would be mandatory.

Upstream framing consists of packets of 512 bits (256 symbols) which are sent in a bursty mode from the different users present on the network. The upstream slot rates are 6000 upstream slots/s when the upstream data rate is 3,088 Mbit/s, 3000 upstream slots/sec when the upstream data rate is 1,544 Mbit/s and 500 upstream slots/sec when the upstream data rate is 256 kbit/s.

## **5.2 Lower Physical Layer Specification**

In this sub-clause, detailed information is given on the lower physical layer specification. The figures 4 and 5 show the conceptual block diagrams for implementation of the present specification.

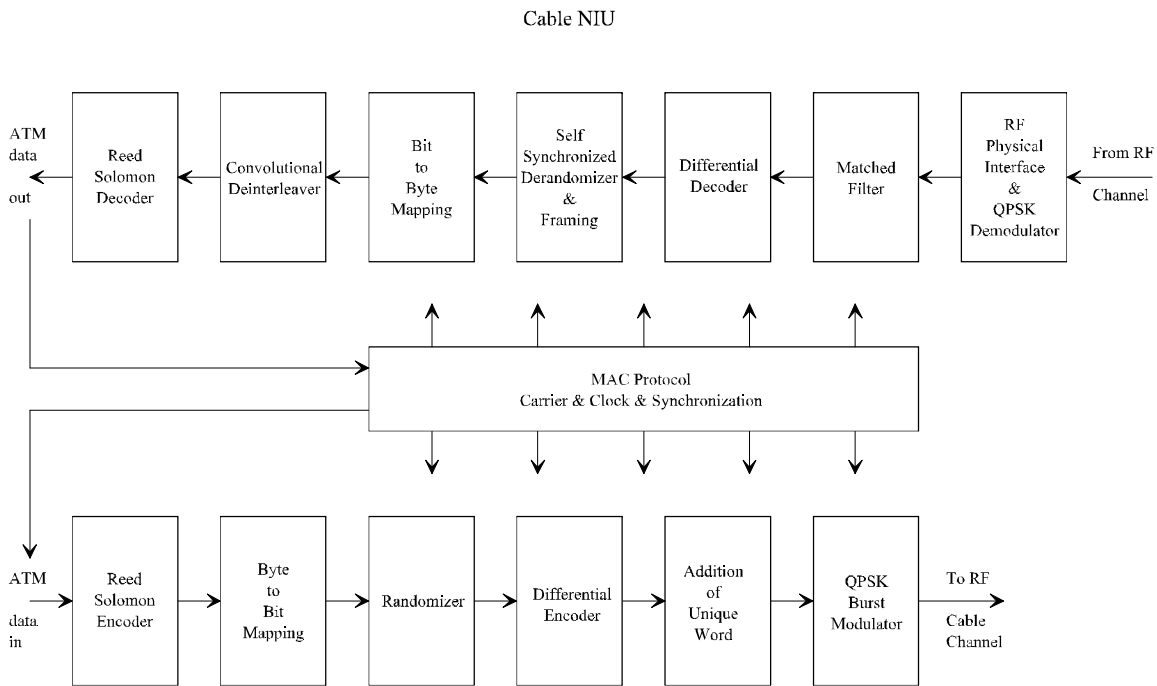

**Figure 4: Conceptual Block Diagram for the NIU OOB Transceiver**

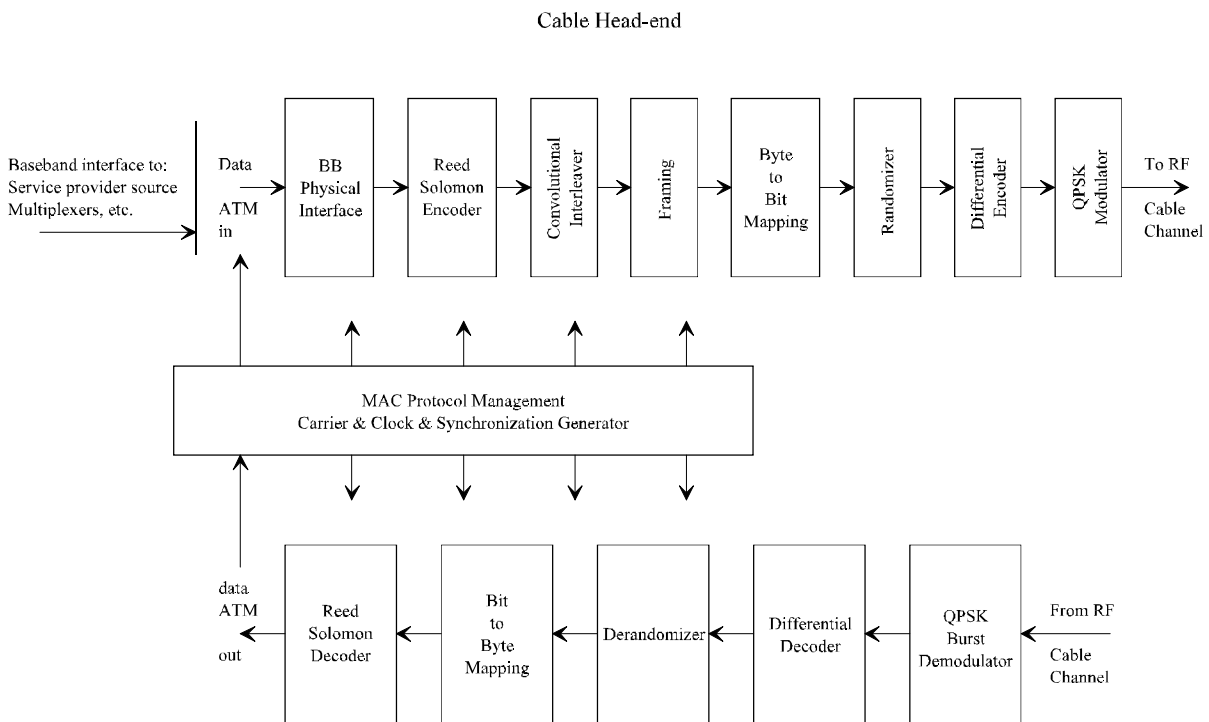

**Figure 5: Conceptual Block Diagram for the OOB Head-End Transceiver**

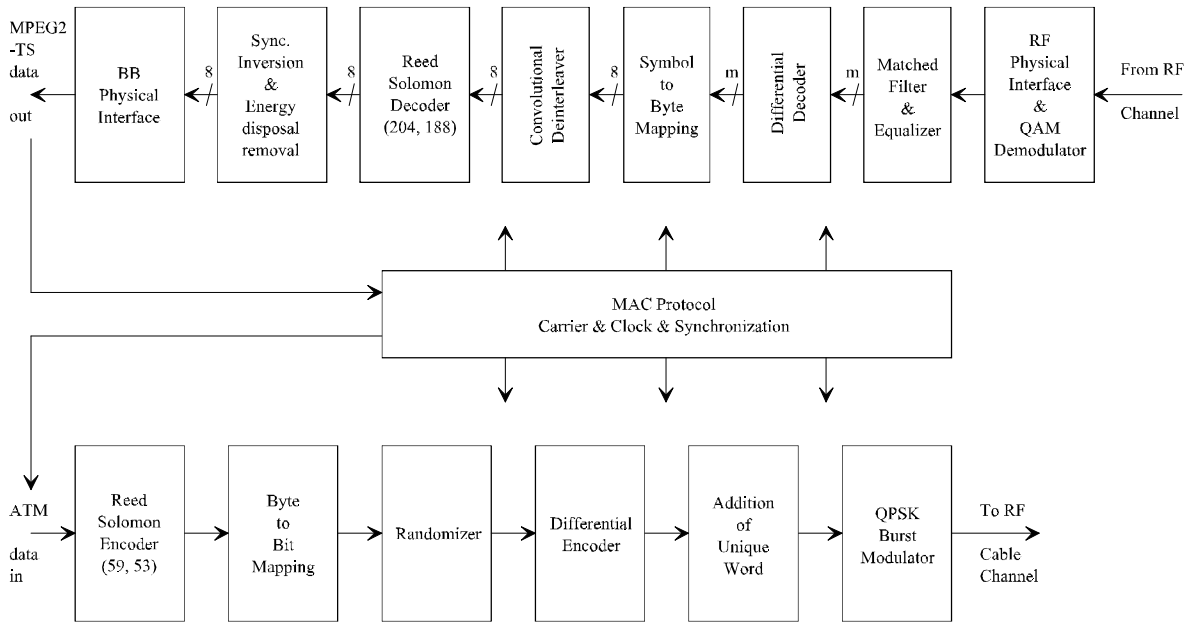

**Figure 6: Conceptual Block Diagram for the IB NIU Transceiver**

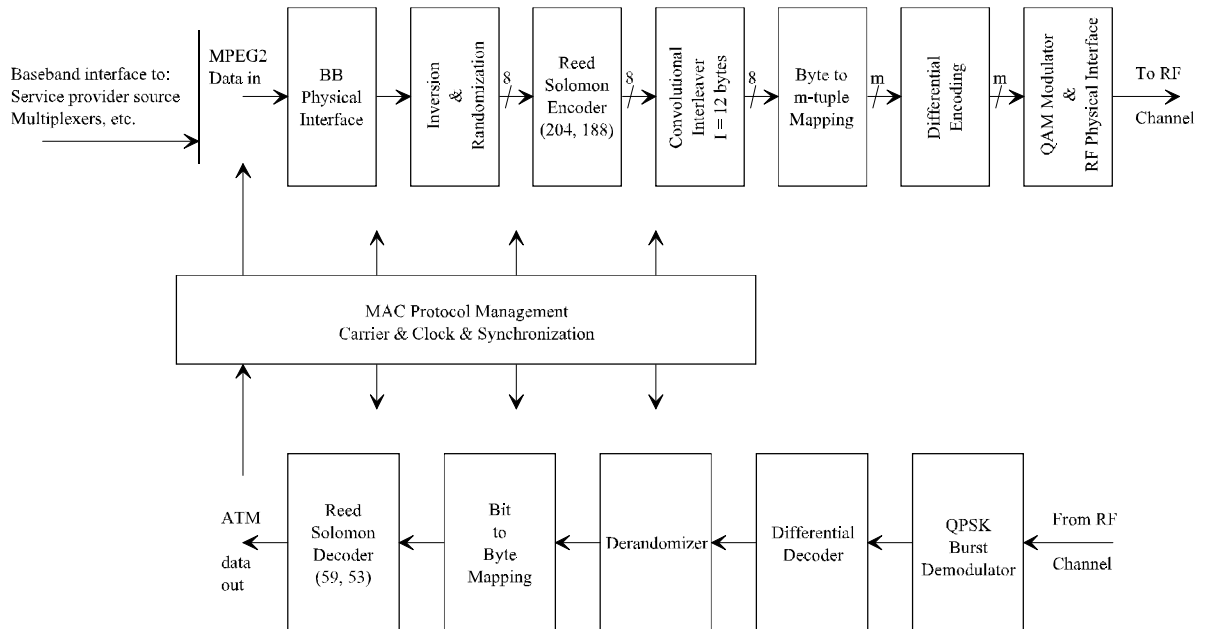

**Figure 7: Conceptual Block Diagram for the IB Head-End Transceiver**

## 5.2.1 Forward Interaction Path (Downstream OOB)

### 5.2.1.1 Frequency Range (Downstream OOB)

The frequency range is not specified as mandatory although a guideline is provided to use the following preferred frequency ranges, 70-130 MHz and/or 300-862 MHz or parts thereof, in order to simplify the tuner of the NIU. Frequency stability shall be in the range +/- 50 ppm measured at the upper limit of the frequency range.

### 5.2.1.2 Modulation and Mapping (Downstream OOB)

QPSK modulation is used as a means of encoding digital information over wireline or fiber transmission links. The method is a subset of Phase Shift Keying (PSK) which is a subset of Phase Modulation (PM). Specifically QPSK is a four level use of digital phase modulation (PM). Quadrature signal

representations involve expressing an arbitrary phase sinusoidal waveform as a linear combination of a cosine wave and a sine wave with zero starting phases.

QPSK systems require the use of differential encoding and corresponding differential detection. This is a result of the receivers having no method of determining if a recovered reference is a sine reference or a cosine reference. In addition, the polarity of the recovered reference is uncertain.

Differential encoding transmits the information in encoded phase differences between the two successive signals. The modulator processes the digital binary symbols to achieve differential encoding and then transmits the absolute phases. The differential encoding is implemented at the digital level.

The differential encoder shall accept bits A, B in sequence, and generate phase changes as follows:

**Table 1: Phase changes associated with bit A, B**

| A | B | Phase Change |
|---|---|--------------|
| 0 | 0 | none         |
| 0 | 1 | + 90°        |
| 1 | 1 | 180°         |
| 1 | 0 | - 90°        |

In serial mode, A arrives first. The outputs I, Q from the differential encoder map to the phase states as in figure 8.

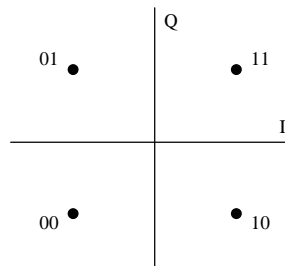

**Figure 8: Mapping for the QPSK constellation (downstream OOB)**

The phase changes can also be expressed by the following formulas (assuming the constellation is mapped from I and Q as shown in 5.2.2.2):

$$\begin{cases} A_k = \overline{(I_{k-1} \oplus Q_{k-1})} \times (Q_{k-1} \oplus Q_k) + \overline{(I_k \oplus Q_{k-1})} \times (I_k \oplus I_{k-1}) \\ B_k = \overline{(I_{k-1} \oplus Q_{k-1})} \times (I_{k-1} \oplus I_k) + \overline{(I_{k-1} \oplus Q_k)} \times (Q_k \oplus Q_{k-1}) \end{cases},$$

where k is the time index.

I/Q amplitude imbalance shall be less than 1.0 dB, and phase imbalance less than 2.0°.

### 5.2.1.3 Shaping filter (Downstream OOB)

The time-domain response of a square-root raised-cosine pulse with excess bandwidth parameter  $\alpha$  is given by:

$$g(t) = \frac{\sin\left[\frac{\pi t}{T}(1-\alpha)\right] + \frac{4\alpha t}{T} \cos\left[\frac{\pi t}{T}(1+\alpha)\right]}{\frac{\pi t}{T} \left[1 - \left(\frac{4\alpha t}{T}\right)^2\right]}$$

where T is the symbol period.

The output signal shall be defined as

$$S(t) = \sum_n [I_n \times g(t - nT) \times \cos(2\pi f_c t) - Q_n \times g(t - nT) \times \sin(2\pi f_c t)]$$

with  $I_n$  and  $Q_n$  equal to  $\pm 1$ , independently from each other, and  $f_c$  the QPSK modulator's carrier frequency.

The QPSK modulator divides the incoming bit stream so that bits are sent alternately to the in-phase modulator I and the out-of-phase modulator Q. These same bit streams appear at the output of the respective phase detectors in the demodulator where they are interleaved back into a serial bit stream.

The occupied bandwidth of a QPSK signal is given by the equation:

$$\text{Bandwidth} = \frac{f_b}{2} (1 + \alpha)$$

$f_b$  = bit rate

$\alpha$  = excess bandwidth = 0,30

The spectral mask is the following:

**Table 2: Spectral mask for QPSK modulated signal**

| BW (MHz) | Response (dB) |
|----------|---------------|
| 0,5      | 0 +/- 0,25    |
| 0,772    | -3 +/- 0,25   |
| 1,0      | -24 +/- 3     |
| 1,08     | < -36         |
| 1,54     | < -40         |
| 1,8      | < -50         |

Carrier suppression must be greater than 30 dB.

#### 5.2.1.4 Randomiser (Downstream OOB)

After addition of the FEC bytes (see sub-clause 5.3), all of the 1,544 Mbit/s (or 3,088 Mbit/s) data is passed through a six register linear feedback shift register (LFSR) randomiser to ensure a random distribution of ones and zeroes. The generating polynomial is:  $x^6 + x^5 + 1$ . Byte/serial conversion shall be MSB first. A complementary self-synchronising de-randomiser is used in the receiver to recover the data.

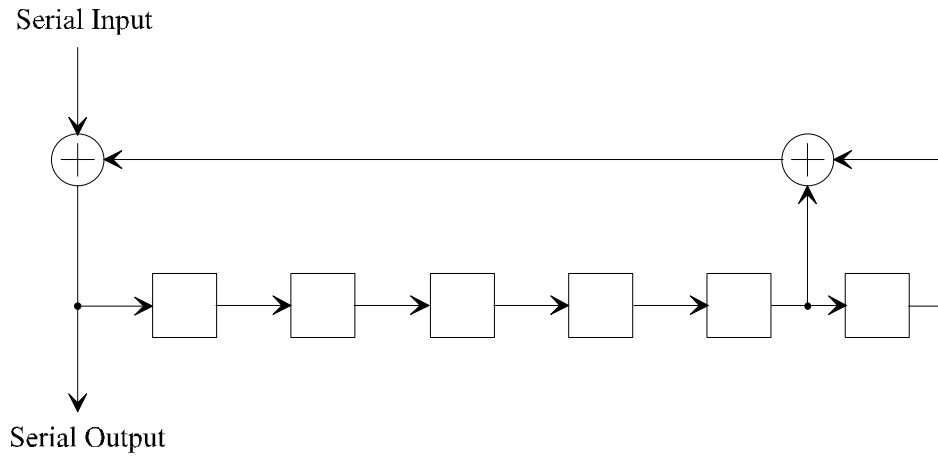

**Figure 9 : Randomiser**

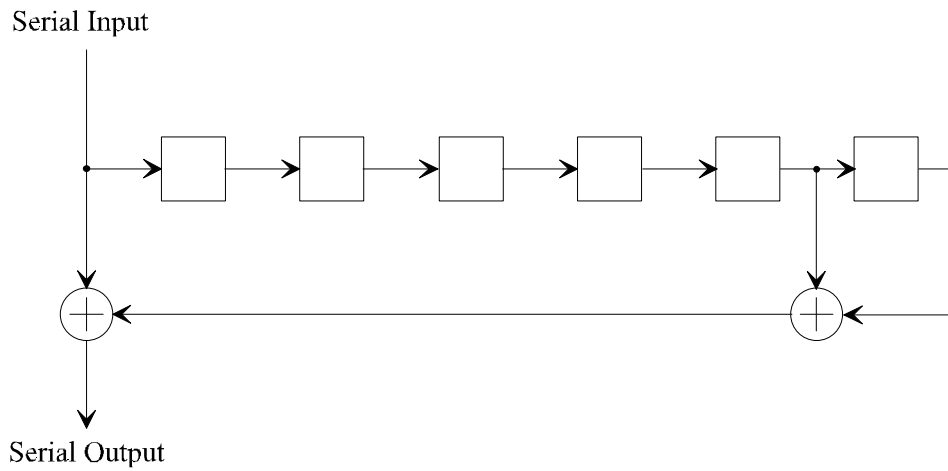

**Figure 10: De-randomiser**

**5.2.1.5 Bit rate (Downstream OOB)**

The bit rate shall be 1,544 Mbit/s or 3,088 Mbit/s. Only one of the bit rates is mandatory in the NIU. Symbol rate accuracy should be within +/- 50 ppm.

**5.2.1.6 Receiver power level (Downstream OOB)**

The receiver power level shall be in the range 42 - 75 dBmicroV (RMS) (75 Ω) at the input (A<sub>b</sub>) reference point.

### 5.2.1.7 Summary (Downstream OOB)

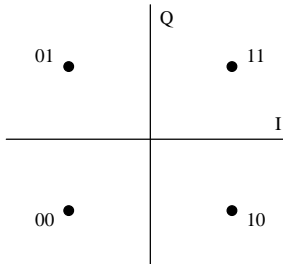
| Transmission Rate      | 1.544 Mbit/s for Grade A<br>3.088 Mbit/s for Grade B  |              |               |              |          |       |             |     |           |       |       |      |       |     |       |          |               |     |            |       |             |     |           |      |       |      |       |
|------------------------|---|--------------|---------------|--------------|----------|-------|-------------|-----|-----------|-------|-------|------|-------|-----|-------|----------|---------------|-----|------------|-------|-------------|-----|-----------|------|-------|------|-------|
| Modulation             | Differentially encoded QPSK.  |              |               |              |          |       |             |     |           |       |       |      |       |     |       |          |               |     |            |       |             |     |           |      |       |      |       |
| Transmit Filtering     | Filtering is alpha = 0,30 square root raised cosine   |              |               |              |          |       |             |     |           |       |       |      |       |     |       |          |               |     |            |       |             |     |           |      |       |      |       |
| Channel Spacing        | 1 MHz for Grade A<br>2 MHz for Grade B  |              |               |              |          |       |             |     |           |       |       |      |       |     |       |          |               |     |            |       |             |     |           |      |       |      |       |
| Frequency Step Size    | 250 kHz (center frequency granularity)  |              |               |              |          |       |             |     |           |       |       |      |       |     |       |          |               |     |            |       |             |     |           |      |       |      |       |
| Randomization          | After addition of the FEC bytes, all of the 1,544 Mbit/s (or 3,088 Mbit/s) data is passed through a six register linear feedback shift register (LFSR) randomiser to ensure a random distribution of ones and zeroes. The generating polynomial is: $x^6 + x^5 + 1$ .<br>Byte/serial conversion shall be MSB first.<br>A complementary self-synchronizing de-randomiser is used in the receiver to recover the data.  |              |               |              |          |       |             |     |           |       |       |      |       |     |       |          |               |     |            |       |             |     |           |      |       |      |       |
| Differential Encoding  | The differential encoder shall accept bits A, B in sequence, and generate phase changes as follows:<br><table border="1" style="margin-left: 20px;"> <thead> <tr> <th>A</th> <th>B</th> <th>Phase Change</th> </tr> </thead> <tbody> <tr> <td>0</td> <td>0</td> <td>none</td> </tr> <tr> <td>0</td> <td>1</td> <td>+ 90°</td> </tr> <tr> <td>1</td> <td>1</td> <td>180°</td> </tr> <tr> <td>1</td> <td>0</td> <td>- 90°</td> </tr> </tbody> </table> In serial mode, A arrives first.   | A            | B             | Phase Change | 0        | 0     | none        | 0   | 1         | + 90° | 1     | 1    | 180°  | 1   | 0     | - 90°    |               |     |            |       |             |     |           |      |       |      |       |
| A                      | B   | Phase Change |               |              |          |       |             |     |           |       |       |      |       |     |       |          |               |     |            |       |             |     |           |      |       |      |       |
| 0                      | 0   | none         |               |              |          |       |             |     |           |       |       |      |       |     |       |          |               |     |            |       |             |     |           |      |       |      |       |
| 0                      | 1   | + 90°        |               |              |          |       |             |     |           |       |       |      |       |     |       |          |               |     |            |       |             |     |           |      |       |      |       |
| 1                      | 1   | 180°         |               |              |          |       |             |     |           |       |       |      |       |     |       |          |               |     |            |       |             |     |           |      |       |      |       |
| 1                      | 0   | - 90°        |               |              |          |       |             |     |           |       |       |      |       |     |       |          |               |     |            |       |             |     |           |      |       |      |       |
| Signal Constellation   | The outputs I, Q from the differential encoder map to the phase states as in figure 11.<br><div style="text-align: center;">  <p>Figure 11</p> </div>   |              |               |              |          |       |             |     |           |       |       |      |       |     |       |          |               |     |            |       |             |     |           |      |       |      |       |
| Frequency Range        | recommended but not mandatory 70 to 130 MHz and/or 300 to 862 MHz   |              |               |              |          |       |             |     |           |       |       |      |       |     |       |          |               |     |            |       |             |     |           |      |       |      |       |
| Frequency Stability    | +/- 50 ppm measured at the upper limit of the frequency range   |              |               |              |          |       |             |     |           |       |       |      |       |     |       |          |               |     |            |       |             |     |           |      |       |      |       |
| Symbol Rate Accuracy   | +/- 50 ppm  |              |               |              |          |       |             |     |           |       |       |      |       |     |       |          |               |     |            |       |             |     |           |      |       |      |       |
| Transmit Spectral Mask | Bit rate = 1.544 Mbit/s (Grade A)<br><table border="1" style="margin-left: 20px;"> <thead> <tr> <th>BW (MHz)</th> <th>Response (dB)</th> </tr> </thead> <tbody> <tr> <td>0.50</td> <td>+/- 0.25</td> </tr> <tr> <td>0.772</td> <td>-3 +/- 0.25</td> </tr> <tr> <td>1.0</td> <td>-24 +/- 3</td> </tr> <tr> <td>1.08</td> <td>&lt; -36</td> </tr> <tr> <td>1.54</td> <td>&lt; -40</td> </tr> <tr> <td>1.8</td> <td>&lt; -50</td> </tr> </tbody> </table><br>Bit rate = 3.088 Mbit/s (Grade B)<br><table border="1" style="margin-left: 20px;"> <thead> <tr> <th>BW (MHz)</th> <th>Response (dB)</th> </tr> </thead> <tbody> <tr> <td>1.5</td> <td>0 +/- 0.25</td> </tr> <tr> <td>1.772</td> <td>-3 +/- 0.25</td> </tr> <tr> <td>2.0</td> <td>-24 +/- 3</td> </tr> <tr> <td>2.08</td> <td>&lt; -36</td> </tr> <tr> <td>2.54</td> <td>&lt; -40</td> </tr> </tbody> </table> | BW (MHz)     | Response (dB) | 0.50         | +/- 0.25 | 0.772 | -3 +/- 0.25 | 1.0 | -24 +/- 3 | 1.08  | < -36 | 1.54 | < -40 | 1.8 | < -50 | BW (MHz) | Response (dB) | 1.5 | 0 +/- 0.25 | 1.772 | -3 +/- 0.25 | 2.0 | -24 +/- 3 | 2.08 | < -36 | 2.54 | < -40 |
| BW (MHz)               | Response (dB)   |              |               |              |          |       |             |     |           |       |       |      |       |     |       |          |               |     |            |       |             |     |           |      |       |      |       |
| 0.50                   | +/- 0.25  |              |               |              |          |       |             |     |           |       |       |      |       |     |       |          |               |     |            |       |             |     |           |      |       |      |       |
| 0.772                  | -3 +/- 0.25   |              |               |              |          |       |             |     |           |       |       |      |       |     |       |          |               |     |            |       |             |     |           |      |       |      |       |
| 1.0                    | -24 +/- 3   |              |               |              |          |       |             |     |           |       |       |      |       |     |       |          |               |     |            |       |             |     |           |      |       |      |       |
| 1.08                   | < -36   |              |               |              |          |       |             |     |           |       |       |      |       |     |       |          |               |     |            |       |             |     |           |      |       |      |       |
| 1.54                   | < -40   |              |               |              |          |       |             |     |           |       |       |      |       |     |       |          |               |     |            |       |             |     |           |      |       |      |       |
| 1.8                    | < -50   |              |               |              |          |       |             |     |           |       |       |      |       |     |       |          |               |     |            |       |             |     |           |      |       |      |       |
| BW (MHz)               | Response (dB)   |              |               |              |          |       |             |     |           |       |       |      |       |     |       |          |               |     |            |       |             |     |           |      |       |      |       |
| 1.5                    | 0 +/- 0.25  |              |               |              |          |       |             |     |           |       |       |      |       |     |       |          |               |     |            |       |             |     |           |      |       |      |       |
| 1.772                  | -3 +/- 0.25   |              |               |              |          |       |             |     |           |       |       |      |       |     |       |          |               |     |            |       |             |     |           |      |       |      |       |
| 2.0                    | -24 +/- 3   |              |               |              |          |       |             |     |           |       |       |      |       |     |       |          |               |     |            |       |             |     |           |      |       |      |       |
| 2.08                   | < -36   |              |               |              |          |       |             |     |           |       |       |      |       |     |       |          |               |     |            |       |             |     |           |      |       |      |       |
| 2.54                   | < -40   |              |               |              |          |       |             |     |           |       |       |      |       |     |       |          |               |     |            |       |             |     |           |      |       |      |       |
| Carrier Suppression    | > 30 dB   |              |               |              |          |       |             |     |           |       |       |      |       |     |       |          |               |     |            |       |             |     |           |      |       |      |       |



|  |                           |
|--|---------------------------|
| Carrier Suppression  | > 30 dB                   |
| I/Q Amplitude Imbalance  | < 1.0 dB                  |
| I/Q Phase Imbalance  | < 2.0°                    |
| Receive Power Level at reference point A <sub>b</sub> (downstream out-of-band) | 42 - 75 dBμV (RMS) (75 Ω) |

|                        |                                      |
|------------------------|--------------------------------------|
| Transmit Spectral Mask | Bit rate = 1.544 Mbit/s (Grade A)    |
|                        | <u>BW (MHz)</u> <u>Response (dB)</u> |
|                        | +/- 0.25                             |
|                        | 0.772        -3 +/- 0.25             |
|                        | 1.0            <-21                  |
| 1.08           <-36    |                                      |
| 1.544           <-40   |                                      |

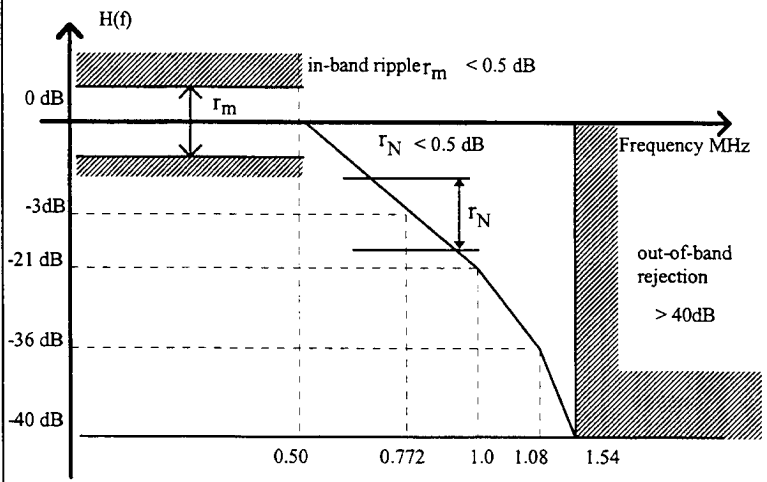

|                        |                                      |
|------------------------|--------------------------------------|
| Transmit Spectral Mask | Bit rate = 3.088 Mbit/s (Grade B)    |
|                        | <u>BW (MHz)</u> <u>Response (dB)</u> |
|                        | 1.0 +/- 0.25                         |
|                        | 1.544        -3 +/- 0.25             |
|                        | 2.0            <-21                  |
|                        | 2.16           <-36                  |
| 3.088           <-40   |                                      |

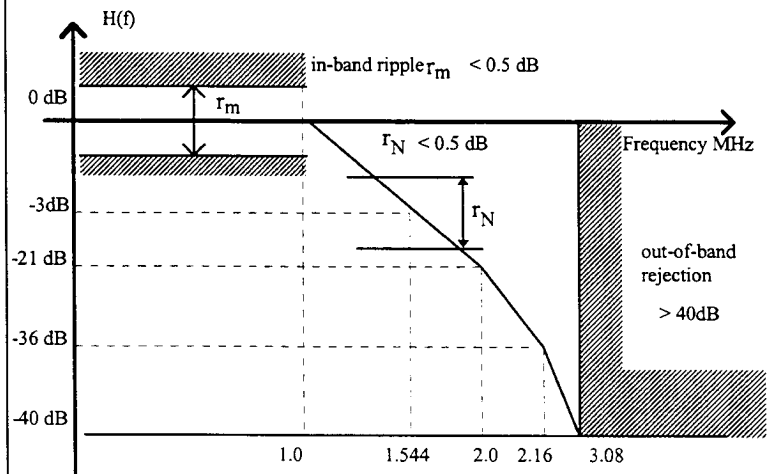

### 5.2.1.8 Bit error rate downstream OOB (Informative)

Bit error rate at the NIU should be less than  $10^{-10}$  (after error correction, i.e. 1 error in 2 hours at 1.5 Mbit/s) at  $C/N > 20$  dB for downstream transmission.  $C/N$  is the carrier-to-noise ratio relevant for the demodulation process (Nyquist bandwidth for white noise).

### 5.2.2 Forward Interaction Path (Downstream IB)

The IB Forward Interaction Path must use a MPEG-2 TS stream with a modulated QAM channel as defined by ETS 300 429. Frequency range, channel spacing, and other lower physical layer parameters should follow that specification.

### 5.2.3 Return Interaction Path (Upstream)

#### 5.2.3.1 Frequency range (Upstream)

The frequency range is not specified as mandatory although a guideline is provided to use the 5-65 MHz. Frequency stability shall be in the range +/- 50 ppm measured at the upper limit of the frequency range.

#### 5.2.3.2 Modulation and Mapping (Upstream)

The unique word (CC CC CC 0D, see sub-clause 5.3 for upstream framing) is not differentially encoded, the outputs I, Q map to the phase states as in figure 12.

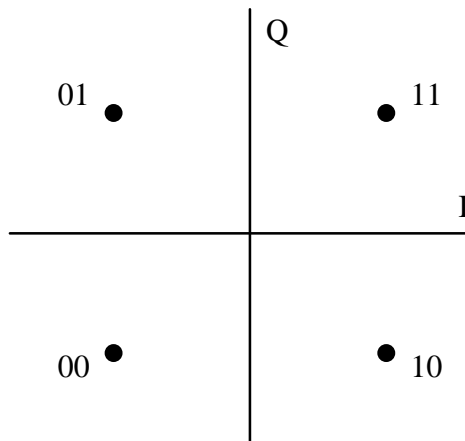

Figure 12: Mapping for the QPSK constellation (upstream)

For the remainder of the packet, the differential encoder shall accept bits A, B in sequence, and generate phase changes as follows. It starts with the first information dibit and is initialised with the last dibit of the unique word, i.e. (A,B = 0,1) since conversion is made MSB first.

Table 3: Phase changes corresponding to bits A, B

| A | B | Phase Change |
|---|---|--------------|
| 0 | 0 | none         |
| 0 | 1 | + 90°        |
| 1 | 1 | 180°         |
| 1 | 0 | - 90°        |

Phase changes correspond to the following formulas (assuming I and Q are mapped to the constellation as for the unique word) :

$$\begin{cases} A_k = \overline{(I_{k-1} \oplus Q_{k-1})} \times (Q_{k-1} \oplus Q_k) + \overline{(I_k \oplus Q_{k-1})} \times (I_k \oplus I_{k-1}) \\ B_k = \overline{(I_{k-1} \oplus Q_{k-1})} \times (I_{k-1} \oplus I_k) + \overline{(I_{k-1} \oplus Q_k)} \times (Q_k \oplus Q_{k-1}) \end{cases}$$

where k is the time index.

I/Q amplitude imbalance shall be less than 1,0 dB, and phase imbalance less than 2,0°.

**5.2.2.3 Shaping filter (Upstream)**

The time-domain response of a square-root raised-cosine pulse with excess bandwidth parameter  $\alpha$  is given by:

$$g(t) = \frac{\sin[\frac{\pi t}{T}(1-\alpha)] + \frac{4\alpha t}{T} \cos[\frac{\pi t}{T}(1+\alpha)]}{\frac{\pi t}{T} [1 - (\frac{4\alpha t}{T})^2]}$$

where T is the symbol period.

The output signal shall be defined as

$$S(t) = \sum_n [I_n \times g(t - nT) \times \cos(2\pi f_c t) - Q_n \times g(t - nT) \times \sin(2\pi f_c t)]$$

with  $I_n$  and  $Q_n$  equal to  $\pm 1$ , independently from each other, and  $f_c$  the QPSK modulator's carrier frequency.

The QPSK modulator divides the incoming bit stream so that bits are sent alternately to the in-phase modulator I and the out-of-phase modulator Q. These same bit streams appear at the output of the respective phase detectors in the demodulator where they are interleaved back into a serial bit stream.

The occupied bandwidth of a QPSK signal is given by the equation:

$$\text{Bandwidth} = \frac{f_b}{2} (1 + \alpha)$$

$f_b$  = bit rate

$\alpha$  = excess bandwidth = 0,30

The spectral mask is the following:

**Table 4: Spectral mask for bit rate = 256 kbit/s (Grade A)**

| BW (MHz) | Response (dB) |
|----------|---------------|
| 89,6     | 0 +/- 0,5     |
| 128      | -3 +/- 0,5    |
| 192      | -24 +/- 3     |
| 1,08     | < -30         |
| 1,544    | < -40         |

**Table 5: Spectral mask for bit rate = 1,544 Mbit/s (Grade B)**

| BW (MHz) | Response (dB) |
|----------|---------------|
| 0,5      | 0 +/- 0,25    |
| 0,772    | -3 +/- 0,25   |
| 192      | -24 +/- 3     |
| 1,08     | < -36         |
| 1,54     | < -40         |

**Table 6: Spectral mask for bit rate = 3.088 Mbit/s (Grade C)**

| BW (MHz) | Response (dB) |
|----------|---------------|
| 1.5      | 0 +/- 0.25    |
| 1.772    | -3 +/- 0.25   |
| 2.0      | -24 +/- 3     |
| 2.08     | < -36         |
| 2.54     | < -40         |

Carrier suppression must be greater than 30 dB.

#### 5.2.3.4 Randomiser (Upstream)

The unique word shall be sent in clear (see sub-clause 5.3). After addition of the FEC bytes, randomisation shall apply only to the payload area and FEC bytes, with the randomiser performing modulo-2 addition of the data with a pseudo-random sequence. The generating polynomial is  $x^6 + x^5 + 1$  with seed all ones. We assume the first value coming out of the pseudo-random generator taken into account is 0. Byte/serial conversion shall be MSB first. The binary sequence generated by the shift register starts with 00000100..... The first "0" is to be added in the first bit after the unique word.

A complementary non self-synchronising de-randomiser is used in the receiver to recover the data. The de-randomiser shall be enabled after detection of the unique word.

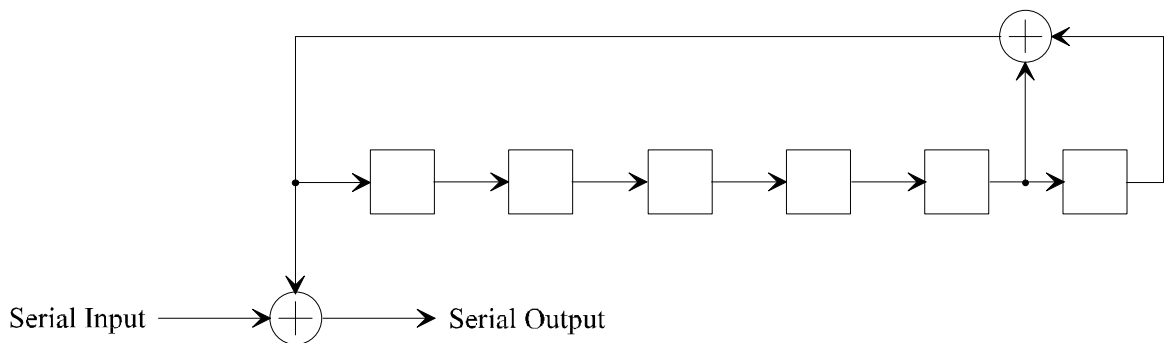

**Figure 13: Randomiser**

#### 5.2.3.5 Bit rate (Upstream)

Three grades of modulation transmission rate are specified:

**Table 7: Upstream bit-rates for modulation grades A, B and C**

| Grade | Rate         |
|-------|--------------|
| A     | 256 kbit/s   |
| B     | 1,544 Mbit/s |
| C     | 3,088 Mbit/s |

A QPSK modulator (NIU transmitter) may support A, B and C grades of transmission rate. [Only the implementation of one of these grades should be mandatory.] A QPSK demodulator (INA receiver) shall support at least one grade A, B or C, but may support all grades.

Symbol rate accuracy should be within +/- 50 ppm.

For grade A, the rate is 500 slots/s. For grade B, the rate is 3000 slots/s. For grade C, the rate is 6000 slots/s.

### **5.2.3.6 Transmit power level (Upstream)**

At the output (reference point A<sub>b</sub>), the transmit power level shall be in the range 85 - 113 dBmicroV (RMS) (75 Ω). In some geographic areas, it may be necessary to cover the range 85-122 dBmicroV (RMS) (75 Ω). However, note that high power may lead to electromagnetic compatibility problems. This power shall be adjusted by steps of 0,5 dB by MAC messages coming from the INA.

### **5.2.3.7 Carrier suppression when idle (Upstream)**

The Carrier Suppression shall be more than 60 dB below nominal power output level, over the entire power output range (The absolute maximum output power level should not exceed that specified in [7]). A terminal is considered to be idle if it is 3 slots before an imminent transmission or 3 slots after its most recent transmission.

### 5.2.3.8 Summary (Upstream)

**Table 8: Summary (Upstream)**

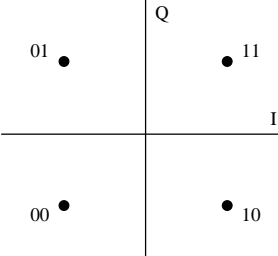
|                       |   |              |      |              |            |   |              |   |              |       |   |   |      |   |   |       |
|-----------------------|---|--------------|------|--------------|------------|---|--------------|---|--------------|-------|---|---|------|---|---|-------|
| Transmission Rate     | <p>Three grades of modulation transmission rate are specified:</p> <table> <tr> <td>Grade</td> <td>Rate</td> </tr> <tr> <td>A</td> <td>256 kbit/s</td> </tr> <tr> <td>B</td> <td>1,544 Mbit/s</td> </tr> <tr> <td>C</td> <td>3,088 Mbit/s</td> </tr> </table> <p>A QPSK modulator (transmitter) may support A, B and C grades of transmission rate. [Only the implementation of one of these grades should be mandatory.] A QPSK demodulator (receiver) shall support at least one grade A, B, or C, but may support both grades.</p>                           | Grade        | Rate | A            | 256 kbit/s | B | 1,544 Mbit/s | C | 3,088 Mbit/s |       |   |   |      |   |   |       |
| Grade                 | Rate  |              |      |              |            |   |              |   |              |       |   |   |      |   |   |       |
| A                     | 256 kbit/s  |              |      |              |            |   |              |   |              |       |   |   |      |   |   |       |
| B                     | 1,544 Mbit/s  |              |      |              |            |   |              |   |              |       |   |   |      |   |   |       |
| C                     | 3,088 Mbit/s  |              |      |              |            |   |              |   |              |       |   |   |      |   |   |       |
| Modulation            | Differentially encoded QPSK   |              |      |              |            |   |              |   |              |       |   |   |      |   |   |       |
| Transmit Filtering    | alpha = 0,30 square root raised cosine  |              |      |              |            |   |              |   |              |       |   |   |      |   |   |       |
| Channel Spacing       | 200 kHz for Grade A (256 kbit/s)<br>1 MHz for Grade B (1,544 Mbit/s)<br>2 MHz for Grade C (3,088 Mbit/s)  |              |      |              |            |   |              |   |              |       |   |   |      |   |   |       |
| Frequency Step Size   | 50 kHz  |              |      |              |            |   |              |   |              |       |   |   |      |   |   |       |
| Randomisation         | <p>The unique word shall be sent in the clear. After addition of the FEC bytes, randomisation shall apply only to the payload area and FEC bytes, with the randomiser performing modulo-2 addition of the data with a pseudo-random sequence. The generating polynomial is <math>x^6 + x^5 + 1</math> with seed all ones.</p> <p>Byte/serial conversion shall be MSB first.</p> <p>A complementary non self-synchronising de-randomiser is used in the receiver to recover the data. The de-randomiser shall be enabled after detection of the unique word.</p> |              |      |              |            |   |              |   |              |       |   |   |      |   |   |       |
| Differential Encoding | <p>The differential encoder shall accept bits A, B in sequence, and generate phase changes as follows. In serial mode, A arrives first.</p> <table> <tr> <td>A</td> <td>B</td> <td>Phase Change</td> </tr> <tr> <td>0</td> <td>0</td> <td>none</td> </tr> <tr> <td>0</td> <td>1</td> <td>+ 90°</td> </tr> <tr> <td>1</td> <td>1</td> <td>180°</td> </tr> <tr> <td>1</td> <td>0</td> <td>- 90°</td> </tr> </table>   | A            | B    | Phase Change | 0          | 0 | none         | 0 | 1            | + 90° | 1 | 1 | 180° | 1 | 0 | - 90° |
| A                     | B   | Phase Change |      |              |            |   |              |   |              |       |   |   |      |   |   |       |
| 0                     | 0   | none         |      |              |            |   |              |   |              |       |   |   |      |   |   |       |
| 0                     | 1   | + 90°        |      |              |            |   |              |   |              |       |   |   |      |   |   |       |
| 1                     | 1   | 180°         |      |              |            |   |              |   |              |       |   |   |      |   |   |       |
| 1                     | 0   | - 90°        |      |              |            |   |              |   |              |       |   |   |      |   |   |       |
| Signal Constellation  | <p>The outputs I, Q from the differential encoder map to the phase states as in figure 14.</p> <p>Note:<br/>The unique word (0x CC CC CC 0D) does not go through differential encoding.</p>   |              |      |              |            |   |              |   |              |       |   |   |      |   |   |       |
| Frequency Range       | 5-65 MHz recommended but not mandatory.   |              |      |              |            |   |              |   |              |       |   |   |      |   |   |       |
| Frequency Stability   | +/- 50 ppm measured at the upper limit of the frequency range   |              |      |              |            |   |              |   |              |       |   |   |      |   |   |       |
| Symbol Rate Accuracy  | +/- 50 ppm  |              |      |              |            |   |              |   |              |       |   |   |      |   |   |       |

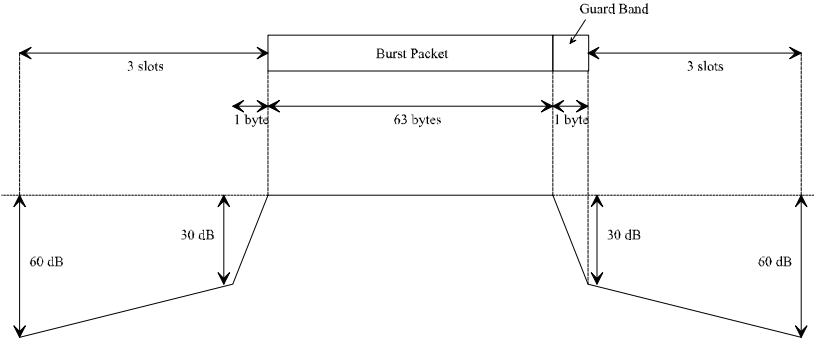
| <b>Transmit Spectral Mask</b>   | <p>Bit rate = 256 kbit/s (Grade A)</p> <table border="1"> <thead> <tr> <th>BW (kHz)</th> <th>Response (dB)</th> </tr> </thead> <tbody> <tr> <td>89,6</td> <td>0 +/- 0,5</td> </tr> <tr> <td>128</td> <td>-3 +/- 0,5</td> </tr> <tr> <td>192</td> <td>&lt; -30</td> </tr> <tr> <td>1 544</td> <td>&lt; -40</td> </tr> </tbody> </table> <p>Bit rate = 1,544 Mbit/s (Grade B)</p> <table border="1"> <thead> <tr> <th>BW (MHz)</th> <th>Response (dB)</th> </tr> </thead> <tbody> <tr> <td>0,5</td> <td>0 +/- 0,25</td> </tr> <tr> <td>0,772</td> <td>-3 +/- 0,25</td> </tr> <tr> <td>1,0</td> <td>-24 +/- 3</td> </tr> <tr> <td>1,08</td> <td>&lt; -36</td> </tr> <tr> <td>1,54</td> <td>&lt; -40</td> </tr> </tbody> </table> <p>Bit rate = 3.088 Mbit/s (Grade C)</p> <table border="1"> <thead> <tr> <th>BW (MHz)</th> <th>Response (dB)</th> </tr> </thead> <tbody> <tr> <td>1.5</td> <td>0 +/- 0.25</td> </tr> <tr> <td>1.772</td> <td>-3 +/- 0.25</td> </tr> <tr> <td>2.0</td> <td>-24 +/- 3</td> </tr> <tr> <td>2.08</td> <td>&lt; -36</td> </tr> <tr> <td>2.54</td> <td>&lt; -40</td> </tr> </tbody> </table> | BW (kHz) | Response (dB) | 89,6 | 0 +/- 0,5 | 128 | -3 +/- 0,5 | 192 | < -30 | 1 544 | < -40 | BW (MHz) | Response (dB) | 0,5 | 0 +/- 0,25 | 0,772 | -3 +/- 0,25 | 1,0 | -24 +/- 3 | 1,08 | < -36 | 1,54 | < -40 | BW (MHz) | Response (dB) | 1.5 | 0 +/- 0.25 | 1.772 | -3 +/- 0.25 | 2.0 | -24 +/- 3 | 2.08 | < -36 | 2.54 | < -40 |
|---|--|----------|---------------|------|-----------|-----|------------|-----|-------|-------|-------|----------|---------------|-----|------------|-------|-------------|-----|-----------|------|-------|------|-------|----------|---------------|-----|------------|-------|-------------|-----|-----------|------|-------|------|-------|
| BW (kHz)  | Response (dB)  |          |               |      |           |     |            |     |       |       |       |          |               |     |            |       |             |     |           |      |       |      |       |          |               |     |            |       |             |     |           |      |       |      |       |
| 89,6  | 0 +/- 0,5  |          |               |      |           |     |            |     |       |       |       |          |               |     |            |       |             |     |           |      |       |      |       |          |               |     |            |       |             |     |           |      |       |      |       |
| 128   | -3 +/- 0,5   |          |               |      |           |     |            |     |       |       |       |          |               |     |            |       |             |     |           |      |       |      |       |          |               |     |            |       |             |     |           |      |       |      |       |
| 192   | < -30  |          |               |      |           |     |            |     |       |       |       |          |               |     |            |       |             |     |           |      |       |      |       |          |               |     |            |       |             |     |           |      |       |      |       |
| 1 544   | < -40  |          |               |      |           |     |            |     |       |       |       |          |               |     |            |       |             |     |           |      |       |      |       |          |               |     |            |       |             |     |           |      |       |      |       |
| BW (MHz)  | Response (dB)  |          |               |      |           |     |            |     |       |       |       |          |               |     |            |       |             |     |           |      |       |      |       |          |               |     |            |       |             |     |           |      |       |      |       |
| 0,5   | 0 +/- 0,25   |          |               |      |           |     |            |     |       |       |       |          |               |     |            |       |             |     |           |      |       |      |       |          |               |     |            |       |             |     |           |      |       |      |       |
| 0,772   | -3 +/- 0,25  |          |               |      |           |     |            |     |       |       |       |          |               |     |            |       |             |     |           |      |       |      |       |          |               |     |            |       |             |     |           |      |       |      |       |
| 1,0   | -24 +/- 3  |          |               |      |           |     |            |     |       |       |       |          |               |     |            |       |             |     |           |      |       |      |       |          |               |     |            |       |             |     |           |      |       |      |       |
| 1,08  | < -36  |          |               |      |           |     |            |     |       |       |       |          |               |     |            |       |             |     |           |      |       |      |       |          |               |     |            |       |             |     |           |      |       |      |       |
| 1,54  | < -40  |          |               |      |           |     |            |     |       |       |       |          |               |     |            |       |             |     |           |      |       |      |       |          |               |     |            |       |             |     |           |      |       |      |       |
| BW (MHz)  | Response (dB)  |          |               |      |           |     |            |     |       |       |       |          |               |     |            |       |             |     |           |      |       |      |       |          |               |     |            |       |             |     |           |      |       |      |       |
| 1.5   | 0 +/- 0.25   |          |               |      |           |     |            |     |       |       |       |          |               |     |            |       |             |     |           |      |       |      |       |          |               |     |            |       |             |     |           |      |       |      |       |
| 1.772   | -3 +/- 0.25  |          |               |      |           |     |            |     |       |       |       |          |               |     |            |       |             |     |           |      |       |      |       |          |               |     |            |       |             |     |           |      |       |      |       |
| 2.0   | -24 +/- 3  |          |               |      |           |     |            |     |       |       |       |          |               |     |            |       |             |     |           |      |       |      |       |          |               |     |            |       |             |     |           |      |       |      |       |
| 2.08  | < -36  |          |               |      |           |     |            |     |       |       |       |          |               |     |            |       |             |     |           |      |       |      |       |          |               |     |            |       |             |     |           |      |       |      |       |
| 2.54  | < -40  |          |               |      |           |     |            |     |       |       |       |          |               |     |            |       |             |     |           |      |       |      |       |          |               |     |            |       |             |     |           |      |       |      |       |
| <b>Carrier Suppression when Transmitter Active</b>                              | <p>&gt; 30 dB</p>  |          |               |      |           |     |            |     |       |       |       |          |               |     |            |       |             |     |           |      |       |      |       |          |               |     |            |       |             |     |           |      |       |      |       |
| <b>Carrier Suppression when Transmitter Idle</b>                                | <p>The Carrier Suppression shall be more than 60 dB below nominal power output level over the entire power output range (see [7] for details) and 30 dB right after or before transmission.</p> <p>Idle Transmitter Definition: A terminal is considered to be idle if it is 3 slots before an imminent transmission or 3 slots after its most recent transmission.</p>    |          |               |      |           |     |            |     |       |       |       |          |               |     |            |       |             |     |           |      |       |      |       |          |               |     |            |       |             |     |           |      |       |      |       |
| <b>I/Q Amplitude Imbalance</b>  | <p>&lt; 1,0 dB</p>   |          |               |      |           |     |            |     |       |       |       |          |               |     |            |       |             |     |           |      |       |      |       |          |               |     |            |       |             |     |           |      |       |      |       |
| <b>I/Q Phase Imbalance</b>  | <p>&lt; 2,0°</p>   |          |               |      |           |     |            |     |       |       |       |          |               |     |            |       |             |     |           |      |       |      |       |          |               |     |            |       |             |     |           |      |       |      |       |
| <b>Transmit Power Level at the modulator output <math>A_b</math> (upstream)</b> | <p>85 - 113 dBmicroV (RMS) (75 <math>\Omega</math> ). In some geographic areas, it may be necessary to cover the range 85 - 122 dBmicroV (RMS) (75 <math>\Omega</math>).</p>   |          |               |      |           |     |            |     |       |       |       |          |               |     |            |       |             |     |           |      |       |      |       |          |               |     |            |       |             |     |           |      |       |      |       |
| <b>Transmit Spectral Mask</b>   | <p>Bit rate = 256 kbit/s (Grade A)</p> <table border="1"> <thead> <tr> <th>BW (kHz)</th> <th>Response (dB)</th> </tr> </thead> <tbody> <tr> <td>89.6</td> <td>0 +/- 0.5</td> </tr> <tr> <td>128</td> <td>-3 +/- 0.5</td> </tr> <tr> <td>192</td> <td>&lt; -30</td> </tr> <tr> <td>1544</td> <td>&lt; -40</td> </tr> </tbody> </table>  | BW (kHz) | Response (dB) | 89.6 | 0 +/- 0.5 | 128 | -3 +/- 0.5 | 192 | < -30 | 1544  | < -40 |          |               |     |            |       |             |     |           |      |       |      |       |          |               |     |            |       |             |     |           |      |       |      |       |
| BW (kHz)  | Response (dB)  |          |               |      |           |     |            |     |       |       |       |          |               |     |            |       |             |     |           |      |       |      |       |          |               |     |            |       |             |     |           |      |       |      |       |
| 89.6  | 0 +/- 0.5  |          |               |      |           |     |            |     |       |       |       |          |               |     |            |       |             |     |           |      |       |      |       |          |               |     |            |       |             |     |           |      |       |      |       |
| 128   | -3 +/- 0.5   |          |               |      |           |     |            |     |       |       |       |          |               |     |            |       |             |     |           |      |       |      |       |          |               |     |            |       |             |     |           |      |       |      |       |
| 192   | < -30  |          |               |      |           |     |            |     |       |       |       |          |               |     |            |       |             |     |           |      |       |      |       |          |               |     |            |       |             |     |           |      |       |      |       |
| 1544  | < -40  |          |               |      |           |     |            |     |       |       |       |          |               |     |            |       |             |     |           |      |       |      |       |          |               |     |            |       |             |     |           |      |       |      |       |

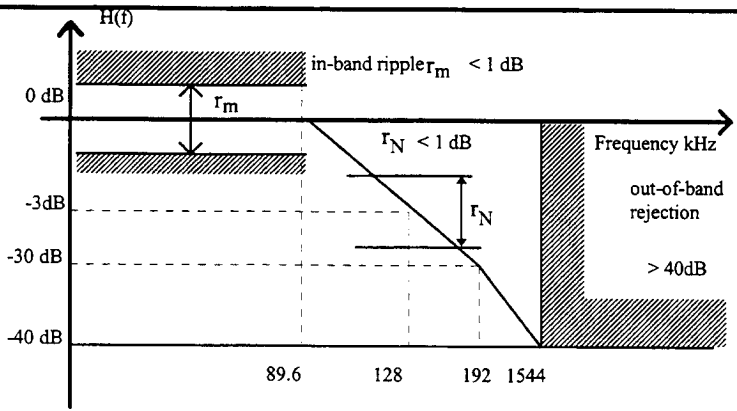

Bit rate = 1.544 Mbit/s (Grade B)

| BW (MHz) | Response (dB) |
|----------|---------------|
| 0.5      | 0 +/- 0.25    |
| 0.772    | -3 +/- 0.25   |
| 1.0      | <-21          |
| 1.08     | <-36          |
| 1.544    | <-40          |

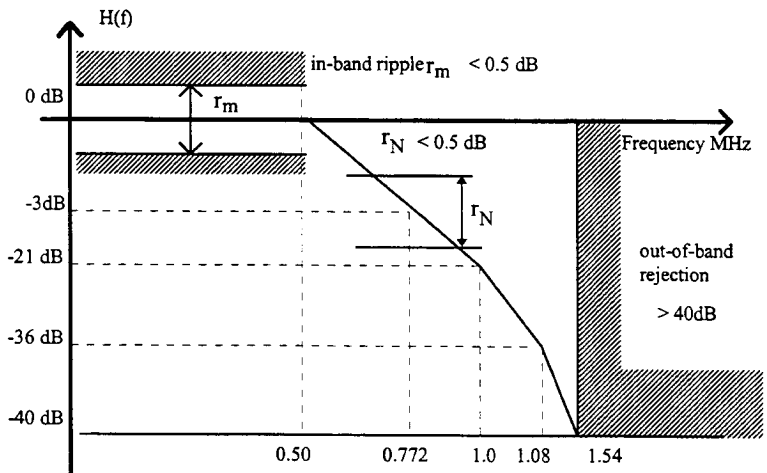

Bit rate = 3.088 Mbit/s (Grade C)

| BW (MHz) | Response (dB) |
|----------|---------------|
| 1.0      | 0 +/- 0.25    |
| 1.544    | -3 +/- 0.25   |
| 2.0      | <-21          |
| 2.16     | <-36          |
| 3.088    | <-40          |



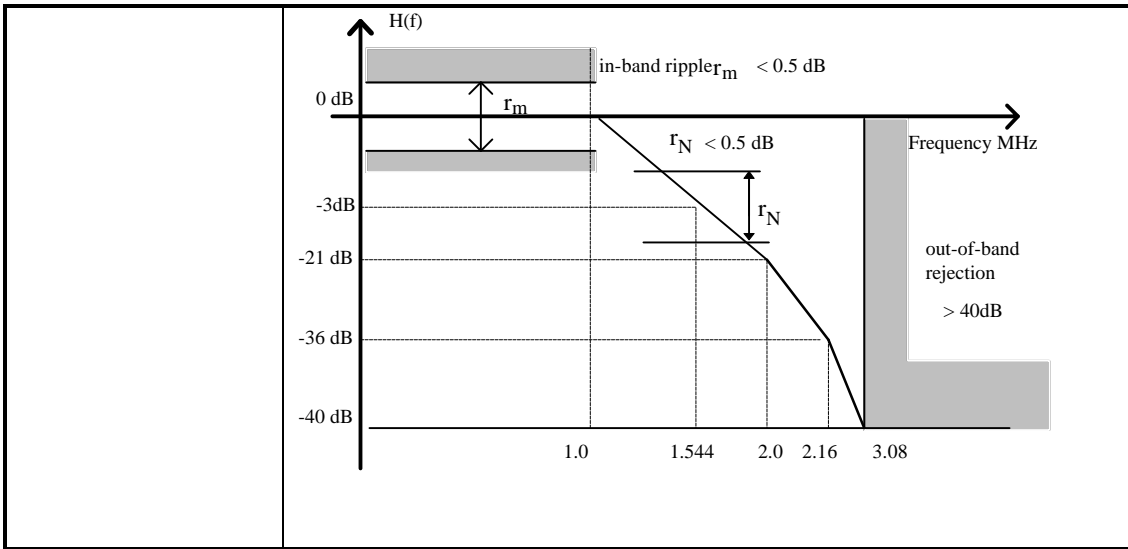

### 5.2.3.9 Packet loss upstream (Informative)

Packet loss at the INA shall be less than  $10^{-6}$  at  $C/N > 20$  dB (after error correction) for upstream transmission.

NOTE: A packet loss occurs when one or more bit per packet (after error correction) are uncorrectable. The  $C/N$  is referred at the demodulator input at the Ax (???) reference point (Nyquist bandwidth, white noise).

[Informative reference: The maximum distance between INA and NIU shall be 50 km. The exact distance is to be checked as well as the rationale for its definition]

## 5.3 Framing

### 5.3.1 Forward Interaction Path (Downstream OOB)

#### 5.3.1.1 Signaling Link Extended Superframe Framing Format

The Signalling Link Extended Superframe (SL-ESF) frame structure is shown in figure 15. The bitstream is partitioned into 4 632-bit Extended Superframes. Each Extended Superframe consists of  $24 \times 193$ -bit frames. Each frame consists of 1 overhead (OH) bit and 24 bytes (192 bits) of payload.

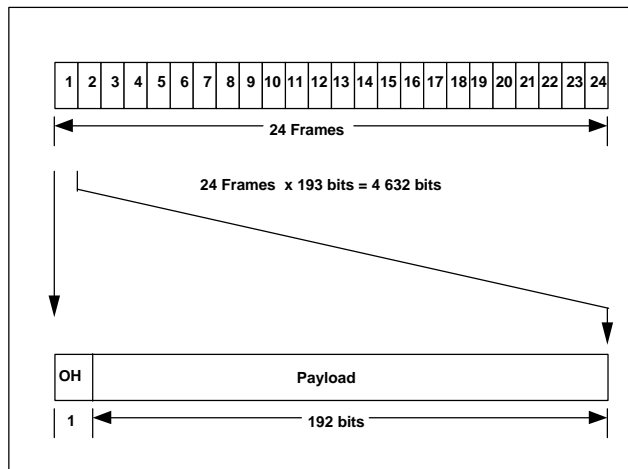

Figure 15: SL-ESF Frame Structure

### 5.3.1.2 Frame overhead

There are 24 frame overhead bits in the Extended Superframe which are divided into Extended Superframe Frame Alignment Signal (F1-F6), Cyclic Redundancy Check (C1-C6), and M-bit Data Link (M1-M12) as shown in table 9.

**Table 9: Frame overhead**

| Frame Number   | Bit Number | Overhead Bit | Data (192 bits) |
|--|------------|--------------|-----------------|
| 1  | 0          | <b>M1</b>    |                 |
| 2  | 193        | C1           |                 |
| 3  | 386        | M2           |                 |
| 4  | 579        | F1 = 0       |                 |
| 5  | 772        | M3           |                 |
| 6  | 965        | C2           |                 |
| 7  | 1 158      | M4           |                 |
| 8  | 1 351      | F2 = 0       |                 |
| 9  | 1 544      | <b>M5</b>    |                 |
| 10   | 1 737      | C3           |                 |
| 11   | 1 930      | M6           |                 |
| 12   | 2 123      | F3 = 1       |                 |
| 13   | 2 316      | M7           |                 |
| 14   | 2 509      | C4           |                 |
| 15   | 2 702      | M8           |                 |
| 16   | 2 895      | F4 = 0       |                 |
| 17   | 3 088      | <b>M9</b>    |                 |
| 18   | 3 281      | C5           |                 |
| 19   | 3 474      | M10          |                 |
| 20   | 3 667      | F5 = 1       |                 |
| 21   | 3 860      | M11          |                 |
| 22   | 4 053      | C6           |                 |
| 23   | 4 246      | M12          |                 |
| 24   | 4 439      | F6 = 1       |                 |
| FAS: Frame Alignment Signal (F1 - F6)<br>DL: Mbit Data Link (M1 - M12)<br>CRC: Cyclic Redundancy Check (C1 - C6) |            |              |                 |

#### ESF Frame Alignment Signal

The ESF Frame Alignment Signal (FAS) is used to locate all 24 frames and overhead bit positions. The bit values of the FAS are defined as follows:

F1 = 0, F2 = 0, F3 = 1, F4 = 0, F5 = 1, F6 = 1.

#### ESF Cyclic Redundancy Check

The Cyclic Redundancy Check field contains the CRC-6 check bits calculated over the previous Extended Superframe (CRC Message block [CMB] size = 4632 bits). Before calculation, all 24 frame overhead bits are equal to "1". All information in the other bit positions is unchanged. The check bit sequence C1-C6 is the remainder after multiplication by  $x^6$  and then division by the generator polynomial  $x^6+x+1$  of the CMB. C1 is the most significant bit of the remainder. The initial remainder value is preset to all zeros.

#### ESF Mbit Data Link

The M-bits in the SL-ESF serve for slot timing assignment (see sub-clause 5.4).

### 5.3.1.3 Payload structure

The SL-ESF frame payload structure provides a known container for defining the location of the ATM cells and the corresponding Reed Solomon parity values. The SL-ESF payload structure is shown in table 10.

**Table 10: ESF Payload structure**

|    |       |     |          |  |  |           |   |
|----|-------|-----|----------|--|--|-----------|---|
|    | ← 2 → |     | ← 53 →   |  |  | ← 2 →     |   |
| 1  | R1a   | R1b | ATM Cell |  |  | RS parity |   |
| 2  | R1c   | R2a |          |  |  | R2<br>b   |   |
| 3  | R2c   | R3a |          |  |  |           |   |
| 4  | R3b   | R3c |          |  |  | R4<br>a   |   |
| 5  | R4b   | R4c |          |  |  |           |   |
| 6  | R5a   | R5b |          |  |  | R5<br>c   |   |
| 7  | R6a   | R6b |          |  |  |           |   |
| 8  | R6c   | R7a |          |  |  | R7<br>b   |   |
| 9  | R7c   | R8a |          |  |  |           |   |
| 10 | R8b   | R8c |          |  |  | T         | T |

The SL-ESF payload structure consists of 5 rows of 57 bytes each, 4 rows of 58 bytes each which includes 1 byte trailer, and 1 row of 59 bytes, which includes a 2 byte trailer. The first bit of the SL-ESF payload structure follows the M1 bit of the SL-ESF frame. The SL-ESF payload fields are defined as follows.

#### ATM Cell Structure

The format for each ATM cell structure is shown in figure 16. This structure and field coding shall be consistent with the structure and coding given in ITU-T Recommendation I.361 for ATM UNI.

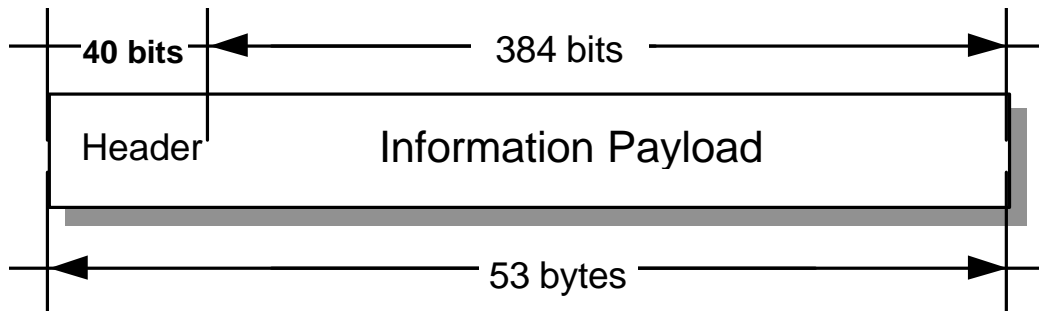

**Figure 16: ATM cell format**

#### Channel coding and interleaving

Reed-Solomon encoding with  $t = 1$  shall be performed on each ATM cell. This means that 1 erroneous byte per ATM cell can be corrected. This process adds 2 parity bytes to the ATM cell to give a codeword of (55,53).

The Reed-Solomon code shall have the following generator polynomials:

**Code Generator Polynomial:**  $g(x) = (x + \mu^0)(x + \mu^1)$ , where  $\mu = 02$  hex

**Field Generator Polynomial:**  $p(x) = x^8 + x^4 + x^3 + x^2 + 1$

Convolutional interleaving shall be applied to the ATM cells contained in the SL-ESF. The Rxa - Rxc bytes and the two T bytes shall not be included in the interleaving process. Convolutional interleaving is applied by interleaving 5 lines of 55 bytes.

Following the scheme of the figure below, convolutional interleaving shall be applied to the error protected packets. The convolutional interleaving process shall be based on the Forney approach, which is compatible with the Ramsey type III approach, with  $I = 5$ . The Interleaved frame shall be composed of overlapping error protected packets and a group of 10 packets shall be delimited by the start of the SL-ESF.

The interleaver is composed of  $I$  branches, cyclically connected to the input byte-stream by the input switch. Each branch shall be a First In First Out (FIFO) shift register, with depth ( $M$ ) cells (where  $M = N/I$ ,  $N = 55 =$  error protected frame length,  $I =$  interleaving depth). The input and output switches shall be synchronised.

For synchronisation purposes, the first byte of each error protected packet shall be always routed into the branch "0" of the interleaver (corresponding to a null delay). The third byte of the SL-ESF payload (the byte immediately following R1b) shall be aligned to the first byte of an error protected packet.

The de-interleaver is similar, in principle, to the interleaver, but the branch indexes are reversed (i.e. branch 0 corresponds to the largest delay). The de-interleaver synchronisation is achieved by routing the third data byte of the SL-ESF into the "0" branch.

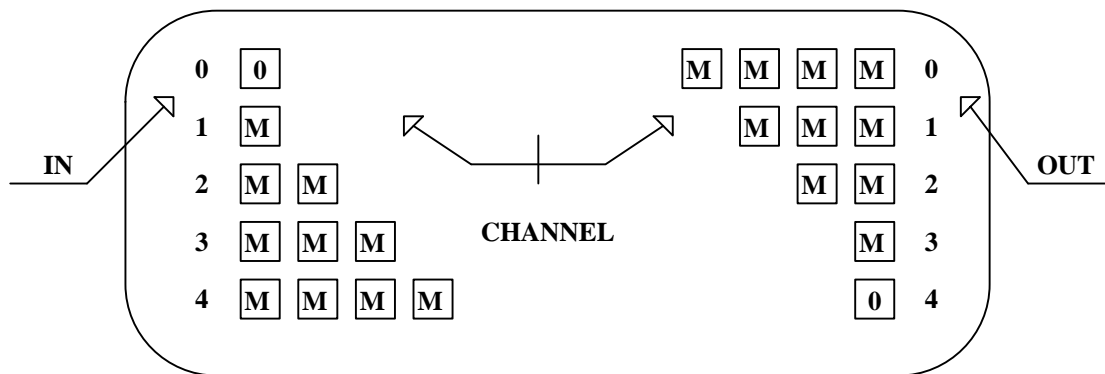

**Figure 17: Interleaver and De-interleaver structures**

### Reception indicator fields and slot boundary fields

Rxa-Rxc is a 24-bit field containing slot configuration information for the upstream channel "x" and is defined as:

- Rxa = (b0 .....b7)
- Rxb = (b8.....b15)
- Rxc = (b16... b23)

= slot configuration information for the upstream channel "x" where "x" is indicated to the NIU in the « Flag set » given in MAC messages (Default Configuration Message, Connect Message, Transmission Control message) corresponding to a particular upstream frequency. Due to the different possible rates upstream (256 kb/s, 1,544 Mb/s, or 3,088 Mb/s), one channel may require up to two consecutive fields. "x" thus denotes first field used for a particular upstream frequency.

|         |   |
|---------|---|
| b0      | = ranging control slot indicator for next superframe        |
| b1-b6   | = slot boundary definition field for next superframe        |
| b7      | = slot 1 reception indicator for second previous superframe |
| b8      | = slot 2 reception indicator for second previous superframe |
| b9      | = slot 3 reception indicator for second previous superframe |
| b10     | = slot 4 reception indicator for second previous superframe |
| b11     | = slot 5 reception indicator for second previous superframe |
| b12     | = slot 6 reception indicator for second previous superframe |
| b13     | = slot 7 reception indicator for second previous superframe |
| b14     | = slot 8 reception indicator for second previous superframe |
| b15     | = slot 9 reception indicator for second previous superframe |
| b16-17  | = reservation control for next superframe                   |
| b18-b23 | = crc 6 parity  |

When the upstream data channel is a 256 kbit/s data channel, then only the first three slot reception indicators are valid. These slots indicators refer to the three available slots which span over two superframe periods in the 256 kbit/s. When the upstream data rate is 1,544 Mbit/s, then the 9 slots are valid. When the data rate is 3,088 Mbit/s, the 9 slots of this field and the 9 slots of the following field are valid.

**Ranging Control Slot Indicator (b0)** - When this bit is active (b0 = 1), the first three slots of upstream channel "x" which correspond to the occurrence of the next superframe of the related downstream channel are designated as ranging control slots. A ranging control message may be transmitted in the second ranging control slot, and the first and third ranging control slots may not be used for transmission (guard band for ranging operations).

**Slot Boundary Definition field (b1-b6)** - Slot types are assigned to upstream slots using bits b0-b6. The slots are grouped into regions within the SL-ESF such that slots of a similar type are contained within the same region. The order of the regions is Ranging slot, Contention based slots, Reserved slots and Fixed rate based slots. If a ranging slot is available within a SL-ESF it will consist of the first three slot times in the SL-ESF. A ranging slot is indicated by b0 = 1. The boundaries between the remaining regions of the SL-ESF are defined by b1-b6. The boundaries are defined as shown in table 11.

**Table 11: Slot Boundary Definition field (b1-b6)**

|            |        |
|------------|--------|
| Boundary 0 |        |
| Boundary 1 | slot 1 |
| Boundary 2 | slot 2 |
| Boundary 3 | slot 3 |
| Boundary 4 | slot 4 |
| Boundary 5 | slot 5 |
| Boundary 6 | slot 6 |
| Boundary 7 | slot 7 |
| Boundary 8 | slot 8 |
| Boundary 9 | slot 9 |

The boundary positions are defined by b1-b6 as shown in table 12.

**Table 12: Boundary positions (b1-b6)**

|                      |   |    |    |    |    |    |    |    |    |    |
|----------------------|---|----|----|----|----|----|----|----|----|----|
| (note 1)<br>(note 2) | 0 | 1  | 2  | 3  | 4  | 5  | 6  | 7  | 8  | 9  |
| 0(note 3)            | 0 | 1  | 2  | 3  | 4  | 5  | 6  | 7  | 8  | 9  |
| 1(note 3)            |   | 10 | 11 | 12 | 13 | 14 | 15 | 16 | 17 | 18 |
| 2(note 3)            |   |    | 19 | 20 | 21 | 22 | 23 | 24 | 25 | 26 |
| 3                    |   |    |    | 27 | 28 | 29 | 30 | 31 | 32 | 33 |
| 4                    |   |    |    |    | 34 | 35 | 36 | 37 | 38 | 39 |
| 5                    |   |    |    |    |    | 40 | 41 | 42 | 43 | 44 |
| 6                    |   |    |    |    |    |    | 45 | 46 | 47 | 48 |
| 7                    |   |    |    |    |    |    |    | 49 | 50 | 51 |
| 8                    |   |    |    |    |    |    |    |    | 52 | 53 |
| 9                    |   |    |    |    |    |    |    |    |    | 54 |

NOTE 1: row = Contention based / Reserved region boundary  
 NOTE 2: column = Reserved packet /Fixed rate based region boundary  
 NOTE 3: When the ranging control slot indicator (b0) is set to "1", the values in rows 0 - 2 are illegal values, and values in row 3 means that there are no aloha slots, because slots 1-3 are defined as ranging control slots.

**Example: b0 = 0, b1-b6 = 22: Contention (1-2), reserved (3-5), Fixed rate (6-9)**

The remaining values of the Slot Boundary Definition Field are provided in table 13.

**Table 13: Slot Boundary Definition Field**

| b1-b6 value | ranging control slots | contention slots | reservation slots | fixed rate slots |
|-------------|-----------------------|------------------|-------------------|------------------|
| 55          | 1-6                   | 7-9              | -                 | -                |
| 56          | 1-6                   | 7-8              | -                 | 9                |
| 57          | 1-6                   | 7                | 8-9               | -                |
| 58          | 1-6                   | 7                | 8                 | 9                |
| 59          | 1-6                   | 7                | -                 | 8-9              |
| 60          | 1-6                   | -                | 7-8               | 9                |
| 61          | 1-6                   | -                | 7                 | 8-9              |
| 62          | 1-6                   | -                | -                 | 7-9              |
| 63          | 1-9                   | -                | -                 | -                |

Note: For b1-b6 = 55 - 63, b0 must be set to 1. Note that for b1-b6 between 55 and 62, two ranging slots are provided (2 and 5).

For b1-b6 = 63, three ranging slots are provided (2, 5, and 8).

The values in the above tables are derived from b1-b6 in the following manner:

$$b1 + (b2 \times 2) + (b3 \times 4) + (b4 \times 8) + (b5 \times 16) + (b6 \times 32)$$

When the upstream data channel is a 256 kbit/s data channel, then only the first three slot boundary positions are valid.

**Slot Reception Indicators (b7 - b15)** - When a slot reception indicator is active ("1"), this indicates that a cell was received without collision. The relationship between a given US slot and its indicator is shown

in Table 13a When the indicator is inactive ("0"), this indicates that either a collision was detected or no cell was received in the corresponding upstream slot.

**Table 13a - Relationship of US slot to DS Indicator**

|        | 1.544M Downstream  | 3.088 Downstream                         |
|--------|--|--|
| 256k   | <p>DS: 1 Frame, I</p> <p>US: 3 slots</p>   | <p>DS: 1 Frame, I</p> <p>US: 3 slots</p> |
| 1.544M | <p>DS: 1 Frame, I</p> <p>US: 9 slots</p>   | <p>DS: 1 Frame, I</p> <p>US: 9 slots</p> |
| 3.088M | <p>DS: 1 Frame, I</p> <p>US: 18 slots</p> <p>Note: 2 Flag Sets used in DS</p>  | <p>DS: 1 Frame, I</p> <p>US: 9 slots</p> |
|        | <p>I indicates the US slot in which Indicators are sent. These indicators are for the DS slots in the shaded area.</p> |  |

**Reservation Control (b16-b17)** - When the reservation control field has the value of 0, no reservation attempts are allowed to be transmitted on the corresponding QPSK upstream channel during the slot positions associated with the next 3 msec period. When the reservation control field has the value of 1, reservation attempts can be made. The values 2 and 3 are reserved.

**CRC 6 Parity (b18-b23)** - This field contain a CRC 6 parity value calculated over the previous 18 bits. The CRC 6 parity value is described in the SL-ESF frame format Section **Erreur! Source du renvoi introuvable..**

In the case where there is more than one OOB DS QPSK channel related to an upstream QPSK channel, the SL-ESF overhead bits and the payload R-bytes shall be identical in those OOB DS channels, with the exception of the overhead CRC (C1-C6) bits, which are specific to each of those OOB DS channels. Such related DS channels shall be synchronised.

The MAC messages that are required to perform the MAC functions for the upstream channel shall be transmitted on each of its related OOB DS channels.

**Trailer bytes**

These bytes are not used. They are equal to 0.

### 5.3.2 Forward Interaction Path (Downstream IB)

The structure that is utilised when the downstream QAM channel is carrying MPEG2-TS packets is shown in figure 18.

|             |               |            |                 |           |            |          |          |          |      |
|-------------|---------------|------------|-----------------|-----------|------------|----------|----------|----------|------|
| 4           | 3             | 2          | 3               | 26        | 26         | 40       | 40       | 40       | 4    |
| MPEG Header | Upstrm Marker | Slot Numbr | MAC Flg Control | MAC Flags | Ext. Flags | MAC msg. | MAC msg. | MAC msg. | rsrv |

**Figure 18: Frame structure (MPEG-2 TS format)**

where

**MPEG Header** is the 4 byte MPEG-2 Transport Stream Header as defined in ISO 13818-1 with a specific PID designated for MAC messages.

**Upstream Marker** is a 24 bit field which provides upstream QPSK synchronisation information. The definition of the field is as follows:

**bit 0: upstream marker enable** (msb)

When this field has the value '1', the slot marker pointer is valid. When this field has the value '0', the slot marker pointer is not valid.

**bit 1-7: reserved**

**bit 8 - 23: upstream slot marker pointer**

The slot marker pointer is a 16 bit integer which indicates the number of "symbol" clocks between the first symbol of the next Sync byte and the next 3msec marker.

**Slot Number** is a 16 bit field which is defined as follows:

**bit 0: slot position register enable** (msb)

When this field has the value '1', the slot position register is valid. When this field has the value '0', the slot position register is not valid.

**bit 1-3: reserved**

**bit 4** is set to the value '1'. This bit is equivalent to M12 in the case of OOB downstream.

**bit 5: odd parity**

This bit provides odd parity for upstream slot position register. This bit is equivalent to M11 in the case of OOB downstream.

**bits 6-15: upstream slot position register**

The upstream slot position register is a 10 bit counter which counts from 0 to n with bit 6 the msb. These bits are equivalent to M10-M1 in the case of OOB downstream.

(see sub-clause 5.4 for more information on the functionality of the upstream slot position register)

**MAC Flag Control** is a 24 bit field (b0,b1,b2...b23) which provides control information which is used in conjunction with the MAC Flags and Extension Flags. The definition of the MAC Flag Control field is as follows:





b15 = slot 9 reception indicator for [second] previous 3 ms period

b16-17 = reservation control for next 3 ms period

b18-b23= CRC 6 parity

The slot configuration fields are used in conjunction with the MAC Flag Control field defined above. Note that when the MAC Flag Control field designates that a 1 msec flag update is enabled; (1) the reception indicators refer to the previous 3 ms period (the bracketed term [second] is omitted from the definition), (2) only the reception indicators which relate to slots which occur during the designated 1 ms period are valid, and (3) the ranging control slot indicator, slot boundary definition field, and reservation control field are valid and consistent during each 3 ms period.

### Extension Flags

Extension Flags is a 26 byte field which is used when one or more 3.088 Mb/s upstream QPSK links are used. The definition of the Extension Flags field is identical to the definition of the MAC Flags field above.

When 3.088 mb/s QPSK upstream links are used, Each 3.088 mb/s upstream channel utilises two consecutive qpsk\_slot\_configuration fields. The definition of the first slot configuration field is unchanged. The definition of the second slot configuration field extends the boundary definition to slots 10 through 18, and the reception indicators cover slots 10 through 18.

### MAC Message

The MAC Message field contains a 40 byte message, the general format defined in the section 5.5.

**reserve field c** is a 4 byte field reserved for future use.

## 5.3.3 Return Interaction Path (Upstream)

### 5.3.3.1 Slot Format

The format of the upstream slot is shown in figure 19 below. A Unique Word (UW) (4 bytes) provides a burst mode acquisition method. The payload area (53 bytes) contains a single message cell. The RS Parity field (6 bytes) provides  $t = 3$  Reed Solomon protection RS(59,53) over the payload area. The Guard band (1 byte) provides spacing between adjacent packets.

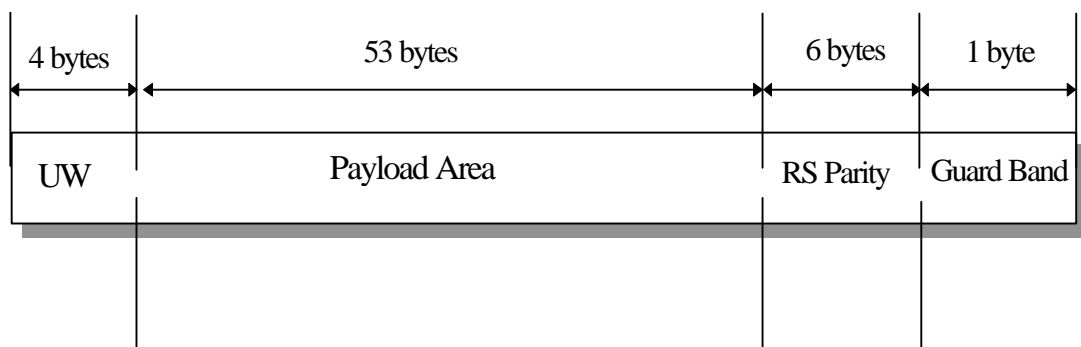

**Figure 19: Slot format**

The structure and field coding of the message cell shall be consistent with the structure and coding given in ITU-T Recommendation I.361 for ATM UNI.

## Unique Word

The unique word is four bytes long : CC CC CC 0D hex

## ATM Cell Structure

The format for each ATM cell structure is illustrated below. This structure and field coding shall be consistent with the structure and coding given in ITU-T Recommendation I.361 for ATM UNI.

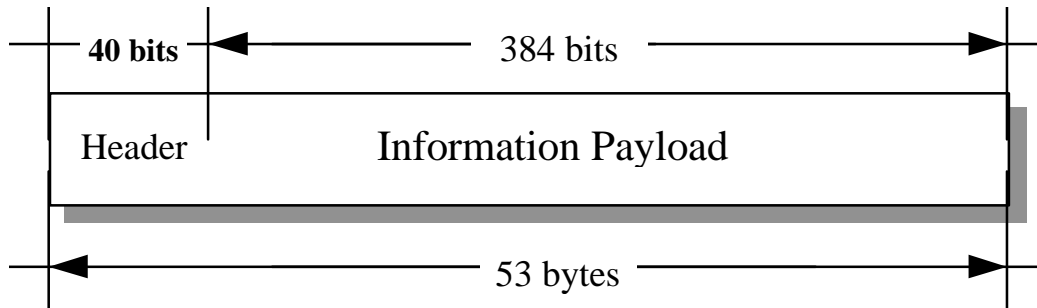

Figure 20: ATM cell format

## Channel Coding

Reed-Solomon encoding shall be performed on each ATM cell with  $T = 3$ . This means that 3 erroneous byte per ATM cell can be corrected. This process adds 6 parity bytes to the ATM cell to give a codeword of (59,53).

The Reed-Solomon code shall have the following generator polynomials:

Code Generator Polynomial:  $g(x) = (x + \mu^0)(x + \mu^1)(x + \mu^2) \dots (x + \mu^5)$ ,

where  $\mu = 02$  hex

Field Generator Polynomial:  $p(x) = x^8 + x^4 + x^3 + x^2 + 1$

## Guard Band

The guard band is 1 byte long (4 QPSK symbols). It provides some extra protection against synchronisation errors.

## 5.4 Slot timing assignment

### 5.4.1 Downstream slot position reference (Downstream OOB)

Upstream synchronisation is derived from the downstream extended superframe (OOB) by noting the slot positions as shown in table 14.

**Table 14: Downstream slot position reference**

| Frame Number | Bit Number | Overhead Bit | Slot position reference      |
|--------------|------------|--------------|------------------------------|
| 1            | 0          | <b>M1</b>    | ◆ Slot Position <sup>1</sup> |
| 2            | 193        | C1           |                              |
| 3            | 386        | M2           |                              |
| 4            | 579        | F1 = 0       |                              |
| 5            | 772        | M3           |                              |
| 6            | 965        | C2           |                              |
| 7            | 1158       | M4           |                              |
| 8            | 1351       | F2 = 0       |                              |
| 9            | 1544       | <b>M5</b>    | ◆ Slot Position              |
| 10           | 1737       | C3           |                              |
| 11           | 1930       | M6           |                              |
| 12           | 2123       | F3 = 1       |                              |
| 13           | 2316       | M7           |                              |
| 14           | 2509       | C4           |                              |
| 15           | 2702       | M8           |                              |
| 16           | 2895       | F4 = 0       |                              |
| 17           | 3088       | <b>M9</b>    | ◆ Slot Position              |
| 18           | 3281       | C5           |                              |
| 19           | 3474       | M10          |                              |
| 20           | 3667       | F5 = 1       |                              |
| 21           | 3860       | M11          |                              |
| 22           | 4053       | C6           |                              |
| 23           | 4246       | M12          |                              |
| 24           | 4439       | F6 = 1       |                              |

<sup>1</sup>: The first slot position is also called the 3 ms time marker in the case of 1,544 Mbit/s rate downstream. For the 3,088 Mbit/s rate downstream, the 3 ms time marker only appears once every two superframes. The M12 bit (see subclause 5.4) is used to differentiate between the two superframes.

### 5.4.2 Downstream slot position reference (Downstream IB)

Upstream synchronisation is derived from the downstream extended superframe (IB) by noting the 3 ms time Marker Downstream as shown in Figure 21. From the bits of the upstream marker field contained in the MPEG-2 TS packet, the 3 ms time Marker is obtained by counting a number of symbol clocks equal to (b23-b8). This marker is equivalent to the first slot position of the superframe for the OOB case.

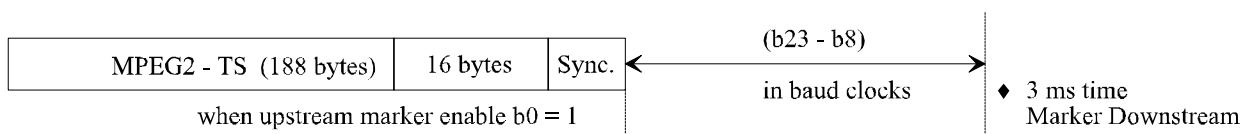

**Figure 21 : Position of the 3 ms time marker for IB signalling**

In order to describe how the Upstream Marker is derived from the location of the 3 msec marker, consider the following system diagram.

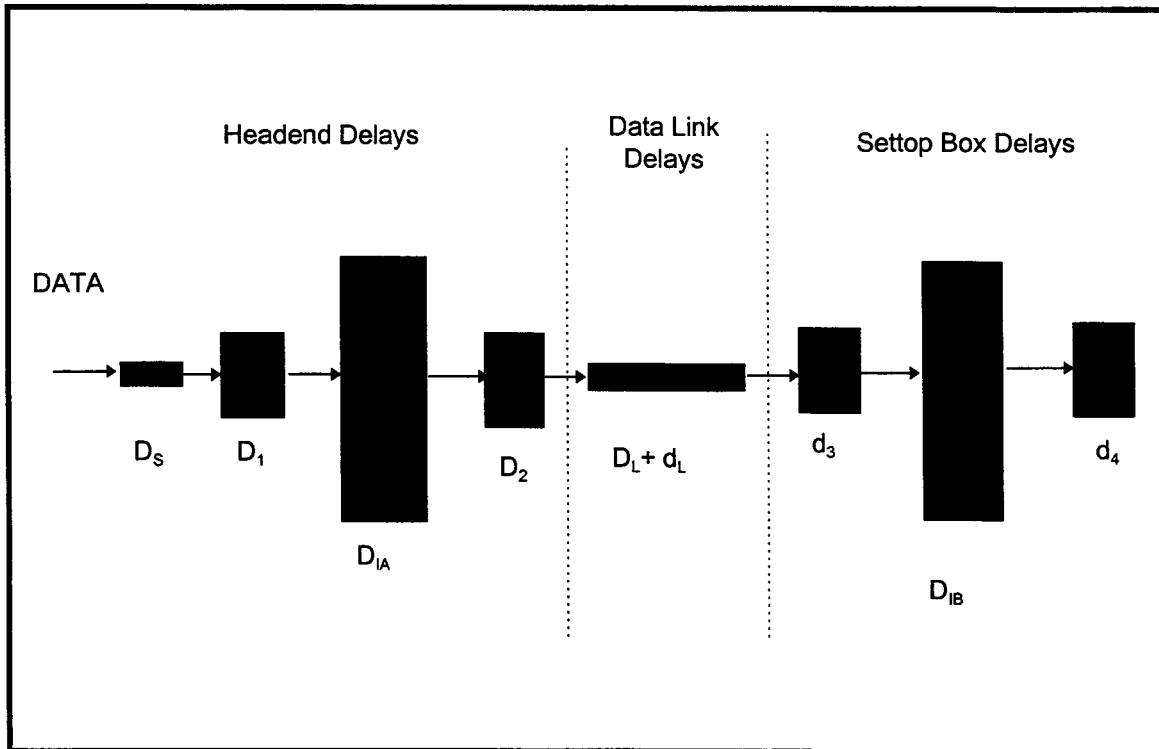

**Figure 22. System Model for Timing Analysis**

The delay between the location of the end of the Upstream Marker and the beginning of the next Sync byte, designated as  $D_s$ , is a constant value for each bit rate equal to the equivalent time of 194 bytes, or

$$(194 * 8 / x) \text{ symbol clocks}$$

where

$$x = 4, \text{ for 16 QAM}$$

$$6, \text{ for 64 QAM}$$

$$8, \text{ for 256 QAM}$$

There will be some processing delay in the Headend hardware between the location where the Upstream Marker is inserted in the MAC packet and the arrival of the data into the interleaver. This should be a constant delay,  $D_1$ , which is the same for every incoming byte, including the sync byte following the Upstream Marker.

The delay due to the interleaving process in the Headend is  $D_{IA}$  and will be zero for each sync byte.

There will be some processing delay in the Headend hardware between the output of the interleaver and the output of the QAM modulator. This should be a constant delay,  $D_2$ , for every byte in the outgoing stream.

The data link is composed of two delay values,  $D_L$ , the constant link delay that every STU experiences, and  $d_L$ , the variable link delay for each STU which is due to the fact that each STU is located at a different distance from the Headend. This variable link delay is compensated for by the ranging operation.

There will be some processing delay in the STU hardware between the input of the QAM demodulator and the input of the de-interleaver. This delay is design dependent,  $d_3$ , and may be a constant delay or a variable delay for each byte in the data stream.

The delay due to the de-interleaving process in the STU is  $D_{IB}$ , and will be equal to the entire interleave delay for each sync byte.

The total interleave delay,

$$D_I = D_{IA} + D_{IB}$$

will be constant for each byte. The value will be given by

$$D_I = 204 * 8 * \text{interleave\_depth} / \text{bit rate}$$

for example, if the modulation is QAM 64 with a baud rate of 5.0 Mb/s,

$$D_I = 204 * 8 * 12 / 30M = 652.8 \text{ microseconds or } 3,264 \text{ symbol clocks}$$

There will be some processing delay in the STU hardware between the output of the de-interleaver and the circuitry that utilises the Upstream marker and following sync byte for generating the local 3 msec marker. This delay, which includes Reed Solomon FEC, is design dependent,  $d_4$ , and may be a constant delay or a variable delay for each byte in the data stream.

The accumulated delay in the data link is composed of a number of constant terms and three variable terms. The constant terms will be identical for every STU that is utilising a particular QAM channel for in-band timing and thus becomes a fixed offset between when the counter which is loading the Upstream Marker value and the actual location of the 3 msec marker at each STU. Each STU is responsible for compensating for the design dependent delays,  $d_3$  and  $d_4$ , before utilising the Upstream Marker value for generating the 3 msec marker. The variable link delay,

$d_L$ , will be compensated for via the ranging algorithm, in the same way as performed when out-of-band signaling is employed.

### 5.4.3 Upstream slot positions

Transmission on each QPSK upstream channel is based on dividing access by multiple NIU units by utilising a negotiated bandwidth allocation slot access method. A slotting methodology allows the transmit slot locations to be synchronised to a common slot position reference, which is provided via the related downstream MAC control channel. Synchronising the slot locations increases message throughput of the upstream channels since the ATM cells do not overlap during transmission.

The slot position reference for upstream slot locations is received via the related downstream MAC control channel by each NIU. Since each NIU receives the downstream slot position reference at a slightly different time, due to propagation delay in the transmission network, slot position ranging is required to align the actual slot locations for each related upstream channel. The upstream slot rates are 6000 upstream slots/sec when the upstream data rate is 3,088 Mbit/s, 3000 upstream slots/sec when the upstream data rate is 1,544 Mbit/s and 500 upstream slots/sec when the upstream data rate is 256 kbit/s.

The number of slots available in any one second is given by:

$$\text{number of slots/sec} = \text{upstream data rate} / 512 + (\text{extra guardband})$$

where extra guardband may be designated between groups of slots for alignment purposes.

The M-bits in the SL-ESF serve two purposes:

- to mark the slot positions for the upstream Contention based and Contentionless based signalling links (see sub-clause 5.4);
- to provide slot count information for upstream message bandwidth allocation management in the NIU.

M-bits M1, M5, and M9 mark the start of an upstream slot position for upstream message transmission.

### 5.4.2.1 Rate 256 kbit/s

In the case where the upstream data rate is 256 kbit/s and the downstream OOB rate is 1,544 Mbit/s, the upstream slots are numbered as follows:

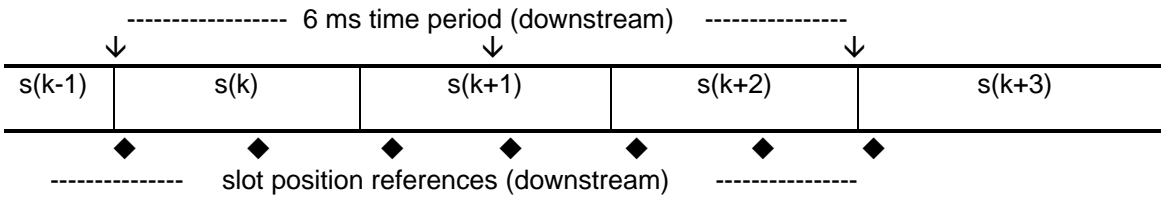

where k is a multiple of 3. In the case where the downstream OOB rate is 3,088 Mbit/s, there are 12 slot position references downstream during the transmission of 3 upstream packets. In the case of IB downstream, packet « k » is sent when the 3 ms time marker is received.

The relationship between the received slot position reference and the actual slot transmit position is given by:

$$\text{slot\_transmit\_position} = \text{slot\_position\_reference (integer)} + \text{slot\_position\_offset}$$

where only the slot\_position\_references corresponding to integer values are valid and

the slot\_position\_offset is derived from the Time\_Offset\_Value provided via the Range\_and\_Power\_Calibration\_Message in the MAC protocol.

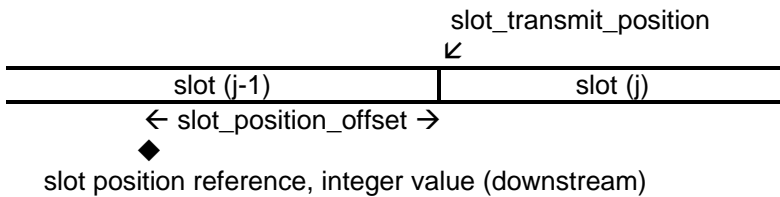

In the case where the upstream data rate is 256 kbit/s, the actual slot transmission locations correspond directly to the integer valued slot position references.

### 5.4.2.2 Rate 1,544 Mbit/s

In the case where the upstream data rate is 1,544 Mbit/s and the downstream OOB rate is 1,544 Mbit/s, the upstream slots are numbered as follows:

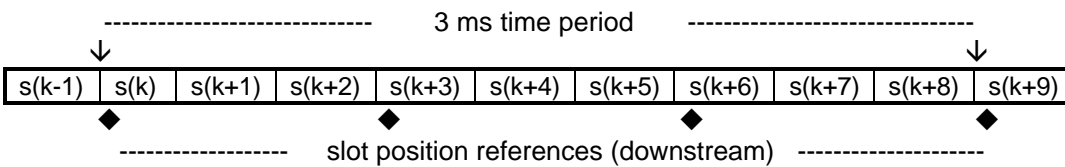

where k is a multiple of 9. In the case where the downstream OOB rate is 3,088 Mbit/s, there are 6 slot position references downstream during the transmission of 9 upstream packets. In the case of IB downstream, packet « k » is sent when the 3 ms time marker is received.

The relationship between the received slot position reference and the actual slot transmit position is given by:

$$\text{slot\_transmit\_position} = \text{slot\_position\_reference} + \text{slot\_position\_offset}$$

where slot\_position\_offset is derived from the Time\_Offset\_Value provided via the Range\_and\_Power\_Calibration\_Message in the MAC protocol.

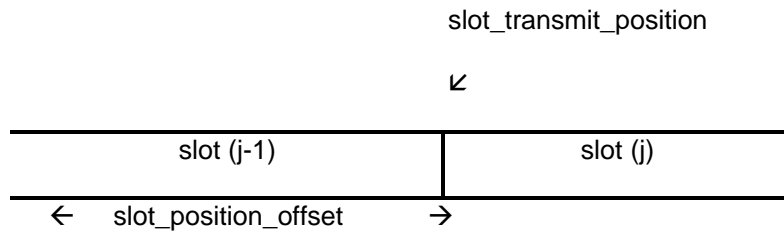

slot position reference (downstream)

In the case where the upstream data rate is 1,544 Mbit/s, the actual slot transmission locations are given by

$$\text{slot\_transmission\_location}(k) = \text{slot\_transmit\_position} + (k \times 512);$$

where  $k = 0,1,2;$  is the position of the slot with respect to the slot\_transmit\_position. This leaves a free time interval before the next slot\_transmit\_position occurs.

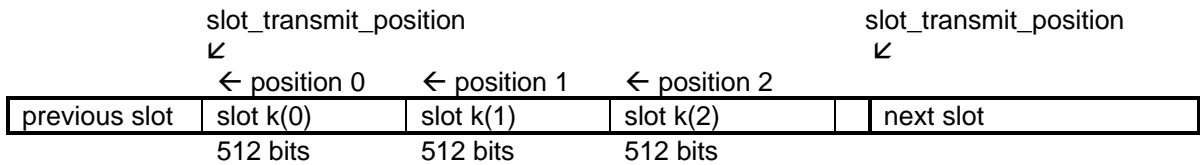

### 5.4.2.3 Rate 3,088 Mbit/s

In the case where the upstream data rate is 3.088 Mbit/s and the downstream OOB rate is 1,544 Mbit/s, the upstream slots are numbered as shown below, where  $k$  is a multiple of 18.

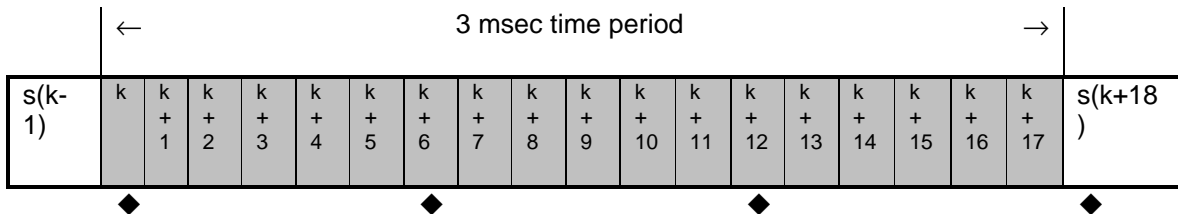

3 slot position references (downstream) per 3 msec time period

In the case where the downstream OOB rate is 3,088 Mbit/s, there are 6 slot position references downstream during the transmission of 18 upstream packets. In the case of IB downstream, packet «  $k$  » is sent when the 3 ms time marker is received.

The relationship between the received slot position reference and the actual slot transmit position is given by:

$$\text{slot\_transmit\_position} = \text{slot\_position\_reference} + \text{slot\_position\_offset}$$

where slot\_position\_offset is derived from the Time\_Offset\_Value provided via the Range\_and\_Power\_Calibration\_Message.



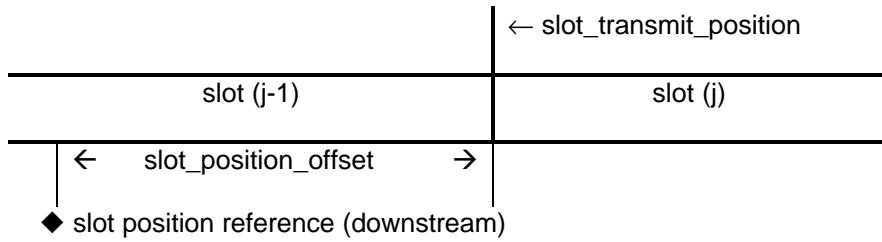

In the case where the upstream data rate is 3.088 Mbit/s, the actual slot transmission locations are given by

$$\text{slot\_transmission\_location (m)} = \text{slot\_transmission\_position} + (m * 512);$$

where  $m = 0,1,2,3,4,5$ ; is the position of the slot with respect to the `slot_transmission_position`

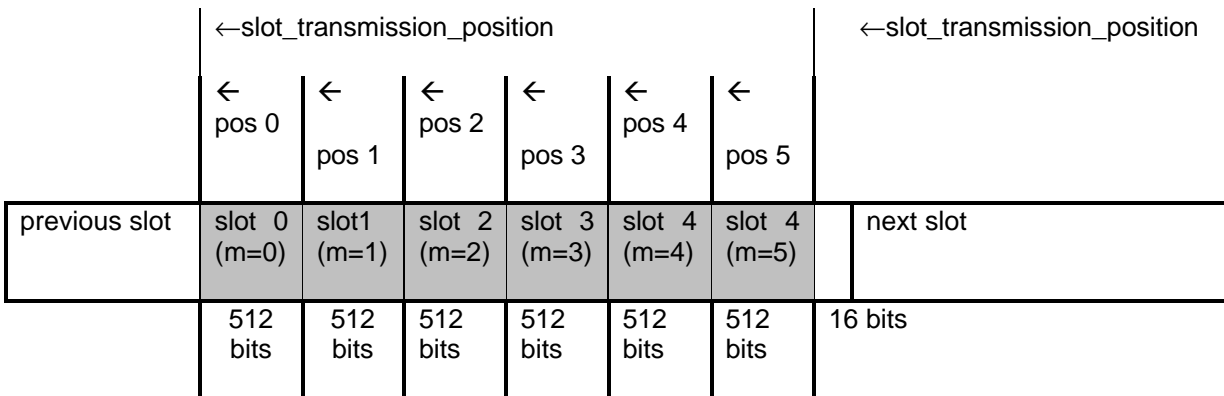

#### 5.4.4 Slot position counter

Think of M-bits M10 - M1 as a register, called the upstream slot position register, which is used to generate an upstream slot position counter, which counts from 0 to n, where n is an integer which indicates slot position cycle size (the value of n is sent in the MAC Default Configuration Message as `Service_Channel_Last_Slot`). The upstream slot position register indicates the upstream slot positions that will correspond to the next SL-ESF frame. Upstream slot positions are counted from 0 to n. There are 6 upstream slots per ms when the upstream data rate is 3,088 Mbit/s, 3 upstream slots per ms when the upstream data rate is 1,544 Mbit/s, and there is 0,5 upstream slot per ms when the upstream data rate is 256 kbit/s. The corresponding upstream slot rates are, therefore, 6000 upstream slots/sec when the upstream data rate is 3,088 Mbit/s, 3000 upstream slots/sec when the upstream data rate is 1,544 Mbit/s, and 500 upstream slots/sec when the upstream data rate is 256 kbit/s. The algorithm to determine the upstream slot position counter value is given below:

```
if (downstream_rate == 3.088 Mbit/s) {n = 1;}
else {n = 0;}
```

```
upstream_slot_position_register = value of M-bits latched at bit_position M11 (M10 - M1)
```

```
if (upstream_rate==1.544 Mbit/s) { m = 3;}
else if (upstream_rate==3.088 Mbit/s) {m = 6;}
else {m = 0.5}
```

```
if ( bit_position==M1 and previous M12 ==1)
{ upstream_slot_position_counter = upstream_slot_register * 3 * m; }
```

```
if ( bit_position == M5)
```

```

if ( (n = 0) or (n == 1 and previous M12 == 0) )
    { upstream_slot_position_counter =
      upstream_slot_position_counter+m; }
if (bit_position == M9)
    if ( (n = 0) or (n = 1 and previous M12 == 1) )
        { upstream_slot_position_counter = upstream_slot_position_counter + m; }
if (bit_position == M11)
    { temp_upstream_slot_position_register = (M10, M9, M8, ....., M1); }
if ( (bit_position == M12 and M12 == 1) )
    {upstream_slot_position = temp_upstream_slot_position_register;}

```

where, the M-bits will be defined as follows:

M1 - M10 = 10 bit ESF counter which counts from 0 to n with M10 the most significant bit (MSB);

M11 = odd parity for the ESF counter, i.e., M11 = 1 if the ESF\_value (M1-M10) has an even number of bits set to 1;

M12 = 1: ESF counter valid  
0; ESF counter not valid

The values assigned to M12 are as follows:

- (1) When the QPSK downstream channel bit rate is 1.544 mb/s, the M12 bit, is always set to the value '1'.
- (2) When the QPSK downstream channel bit rate is 3.088 mb/s, the information is always transmitted in pairs of superframe, where superframe-A is the first superframe in the pair, and superframe-B is the second superframe in the pair. In this case, the M12 bit of superframe-A is set to the value '0' and the M12 bit of superframe-B is set to the value '1'.
- (3) When the downstream channel is IB, M12 = 1.

## **5.5 MAC Functionality**

### **5.5.1 MAC Reference Model**

The scope of this sub-clause is limited to the definition and specification of the MAC Layer protocol. The detailed operations within the MAC layer are hidden from the above layers.

This sub-clause focuses on the required message flows between the INA and the NIU for Media Access Control. These areas are divided into three categories: Initialisation, Provisioning and Sign On Management, Connection Management and Link Management.

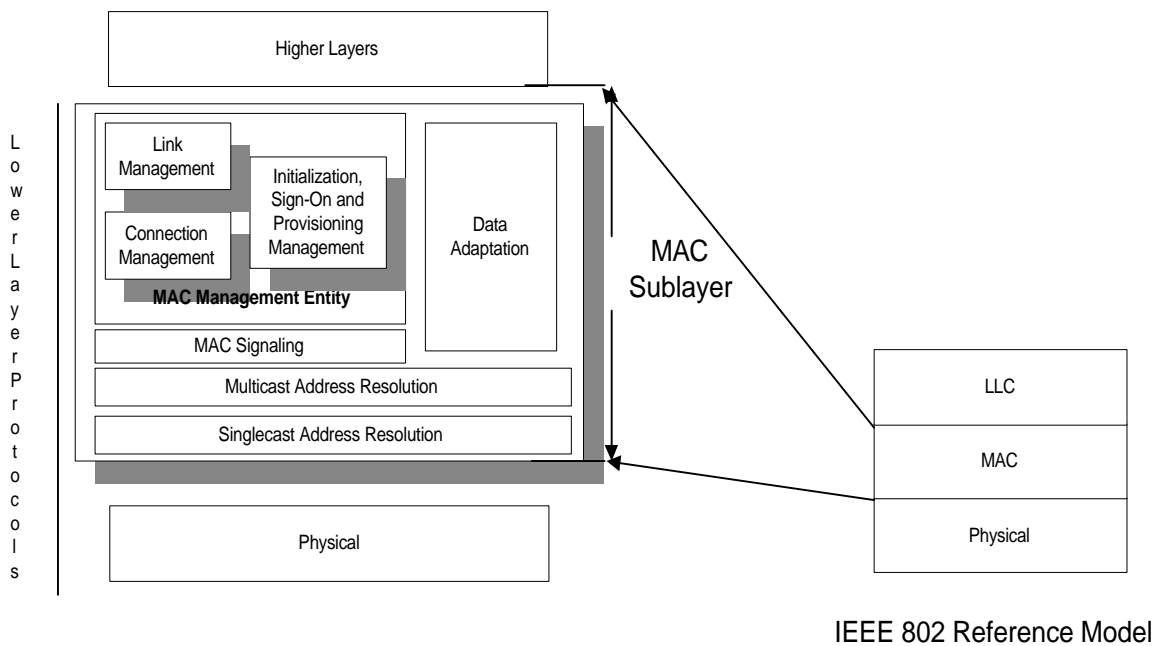

**Figure 23: MAC Reference Model**

## 5.5.2 MAC Concept

### 5.5.2.1 Relationship between higher layers and MAC protocol

The goal of the MAC protocol is to provide tools for higher layer protocols in order to transmit and receive data transparently and independently of the physical layer. Higher layer services are provided by the INA to the STU. The INA is thus responsible of indicating the transmission mode and rate to the MAC layer for each type of service.

Specifically, for each connection provided by higher layers on the INA side (VPI/VCI), a connection ID is associated at the MAC layer. The maximum number of simultaneous connections that a NIU should support is defined as follows:

- Grade A : Only one connection at a time can be handled by a NIU
- Grade B : As many connections as needed, defined dynamically by the INA, following higher layers requests.

Note however, that bandwidth (time slots) does not need to be assigned immediately by the INA for a given connection. This means that a connection ID may exist at the NIU side without associated slot numbers.

The INA is responsible of providing transmission bandwidth to the NIUs when needed by higher layers. However, since the NIU must transmit all data from the STU, the NIU is also responsible for requesting for more bandwidth if not already provided by the INA.

A default connection is initiated by the INA when STBs are first turned on. This connection can be used to send data from higher layers leading to further interactive connections. Note that this connection can be associated to a zero transmission rate (no initial bandwidth allocation).

### 5.5.2.2 Relationship between physical layer and MAC protocol

Up to 8 QPSK Upstream channels can be related to each downstream channel which is designated as a MAC control channel. An example of frequency allocation is shown in the figure 24. This relationship consists of the following items:

- 1) Each of these related upstream channels share a common slot position. This reference is based on 1 millisecond time markers that are derived via information transmitted via the downstream MAC control channel.
- 2) Each of these related upstream channels derive slot numbers from information provided in the downstream MAC control channel.
- 3) The Messaging needed to perform MAC functions for each of these related upstream channels is transmitted via the downstream MAC control channel.

The Media Access Control Protocol supports multiple downstream Channels. In instances where multiple Channels are used, the INA shall specify a single OOB frequency called the Provisioning Channel, where NIU's perform Initialisation and Provisioning Functions. If both 1,544 Mbit/s and 3,088 Mbit/s downstream OOB channels coexist on the network, there should be one provisioning channel with each rate. Also, in networks where IB NIUs exist, provisioning should be included in at least one IB channel. An aperiodic message is sent on each downstream control channel which points to the downstream Provisioning Channel. In instances where only a single frequency is in use, the INA shall utilise that frequency for Initialisation and Provisioning functions.

The Media Access Control protocol supports multiple upstream channels. One of the upstream channels shall be designated the Service Channel. The Service Channel shall be used by NIU's entering the network via the Initialisation and Provisioning procedure. The remaining upstream channels shall be used for upstream data transmission. In cases where only one upstream channel is utilised, the functions of the Service Channel shall reside in conjunction with regular upstream data transmission.

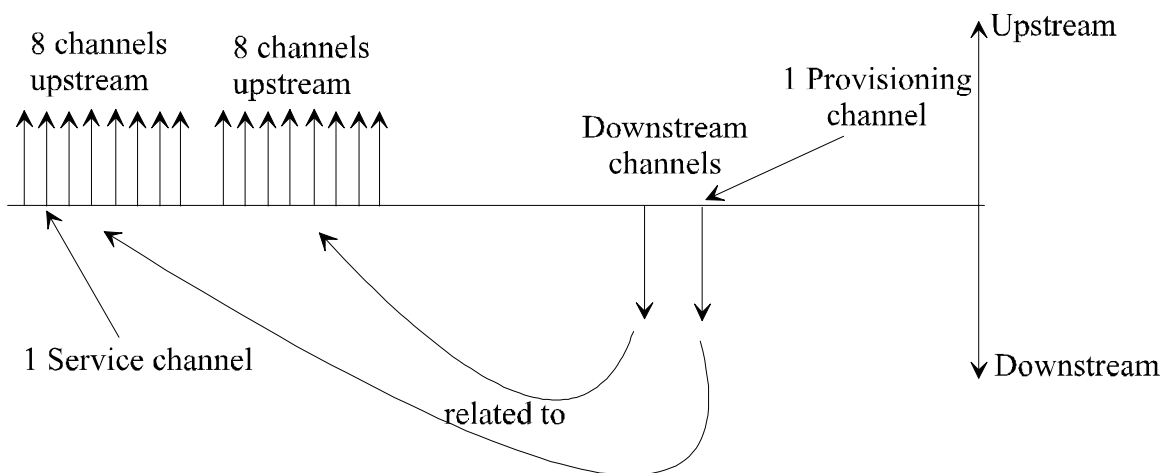

Figure 24: Example of frequency allocation

### 5.5.2.3 Relationship between physical layer slot position counter and MAC slot assignment

M10 - M1 is a 10-bit superframe counter at the INA side, whereas the upstream slot position counter is an upstream slot counter at the NIUs side. The NIU slot position counter ( $M10 - M1 \times 3 \times m$ , where  $m = 3$  for 1,544 Mbit/s and  $m=6$  for 3,088 Mbit/s) may be implemented as a 16-bit counter which is compared to the 16-bit slot numbers assigned by the INA in MAC messages (list assignment). When the counter value equals any assigned value, the NIU is allowed to send a packet upstream.

Note in the algorithm given in subclause 5.4.3 that the counter value is refreshed every time M11 is received.

#### 5.5.2.4 Access modes (Contention / Ranging / Fixed rate / Reservation)

Different access modes are provided to the NIUs within access regions specified by information contained in the slot boundary fields of the downstream superframes. The limits between access regions allow users to know when to send data on contention without risks of collision with contentionless type data. The following rules define how to select access modes:

- Data connections:

When the INA assigns a connection ID to the NIU, it either specifies a slot list to be used (Fixed rate access) or the NIU shall use contention or reserved access by following this algorithm:

- When the NIU must send more cells than what was assigned by the INA, it can use contention access only if the number of cells to transmit is less than `Maximum_contention_access_message_length` (specified in the MAC Connect Message from the INA). In that case, it must wait for the slot reception indicator before it is allowed to send other cells with the same VPI/VCI value. The NIU can send one request for reservation access if the number of cells is less than `Maximum_reservation_access_message_length` (specified in the MAC Connect Message from the INA). If more cells must be transmitted, the NIU must send multiple requests for reservation access.

- MAC messages:

- MAC messages can be sent on contention access or reservation access. MAC messages sent upstream must be less than 40 bytes long. If the MAC information exceeds 40 bytes, it must be segmented into multiple 40 bytes independent MAC messages. Ranging access can only be used for specific MAC messages.

##### a) Contention Access

`Contention Access` indicates that data (MAC or bursty data traffic) is sent in the slots assigned to the contention access region in the upstream channel. It can be used either to send MAC messages or data. The VPI, VCI of the ATM cells are then used to determine the type and direction of the data in higher layers. Contention based access provides instant channel allocation for the NIU.

The Contention based technique is used for multiple subscribers that will have equal access to the signalling channel. It is probable that simultaneous transmissions will occur. For each ATM cell transmitted by the NIU, a positive acknowledgement is sent back by the INA, utilising the reception indicator field, for each successfully received ATM cell. In contention based access mode, a positive acknowledgement indicates that a collision did not occur. A collision occurs if two or more NIUs attempt ATM cell transmission during the same slot. A collision will be assumed if a NIU does not receive a positive acknowledgement. If a collision occurs, then the NIU will retransmit using a procedure to be defined.

##### b) Ranging Access

`Ranging access` indicates that the data is sent in a slot preceded and followed by slots not used by other users. These slots allow users to adjust their clock depending on their distance to the INA such that their slots fall within the correct allocated time. They are either contention based when the ranging control slot indicator **b0** received during the previous superframe was 1 (or when  $b1-b6 = 55$  to  $63$ ), or reserved if the INA indicates to the NIU that a specific slot is reserved for ranging.

##### c) Fixed rate Access

NOTE: Fixed rate is called TDMA in DAVIC.

`Fixedrate Access` indicates that data is sent in slots assigned to the Fixed rate based access region in the upstream channel. These slots are uniquely assigned to a connection by the INA. No fixed rate access can be initiated by the NIU.

## d) Reservation Access

Reservation Access implies that data is sent in the slots assigned to the reservation region in the upstream channel. These slots are uniquely assigned on a frame by frame basis to a connection by the INA. This assignment is made at the request of the NIU for a given connection.

### 5.5.2.5 MAC Error Handling Procedures

Error handling procedures are under definition (Time out windows, retransmission, power outage, etc.)

### 5.5.2.5 MAC messages

The MAC message types are divided into the logical MAC states of Initialisation, Sign On, Connection Management and Link Management. Messages in *Italic* represent upstream transmission from NIU to INA. MAC messages are sent using Broadcast or Singlecast Addressing. Singlecast address shall utilise the 48-bit MAC address.

**Table 15: MAC messages**

| Message Type Value |   | Addressing Type |
|--------------------|---|-----------------|
|                    | <b>MAC Initialization, Provisioning and Sign-On Message</b> |                 |
| 0x01               | Provisioning Channel Message                                | Broadcast       |
| 0x02               | Default Configuration Message                               | Broadcast       |
| 0x03               | Sign-On Request Message                                     | Broadcast       |
| 0x04               | <i>Sign-On Response Message</i>                             | Singlecast      |
| 0x05               | Ranging and Power Calibration Message                       | Singlecast      |
| 0x06               | <i>Ranging and Power Calibration Response Message</i>       | Singlecast      |
| 0x07               | Initialization Complete Message                             | Singlecast      |
| 0x08-0x1F          | [Reserved]  |                 |
|                    | <b>MAC Connection Establishment and Termination Msgs</b>    |                 |
| 0x20-0x3F          |   |                 |
| 0x20               | Connect Message   | Singlecast      |
| 0x21               | <i>Connect Response Message</i>                             | Singlecast      |
| 0x22               | <i>Reservation Request Message</i>                          | Singlecast      |
| 0x23               | Reservation Response Message                                | Broadcast       |
| 0x24               | Connect Confirm Message                                     | Singlecast      |
| 0x25               | Release Message   | Singlecast      |
| 0x26               | <i>Release Response Message</i>                             | Singlecast      |
| 0x27               | <i>Idle Message</i>   | Singlecast      |
| 0x28               | Reservation Grant Message                                   | Broadcast       |
| 0x29               | Reservation ID Assignment                                   | Singlecast      |
| 0x2A               | <i>Reservation Status Request</i>                           | Singlecast      |
| 0x2B               | <i>Reservation ID Response Message</i>                      | Singlecast      |
| 0x2C-0x3F          | [Reserved]  |                 |
|                    | <b>MAC Link Management Messages</b>                         |                 |
| 0x27               | <i>Idle Message</i>   | Singlecast      |
| 0x40               | Transmission Control Message                                | Scast or Bcast  |
| 0x41               | Reprovision Message   | Singlecast      |
| 0x42               | <i>Link Management Response Message</i>                     | Singlecast      |
| 0x43               | Status Request Message                                      | Singlecast      |
| 0x44               | <i>Status Response Message</i>                              | Singlecast      |
| 0x45-0x5F          | [Reserved]  |                 |

To support the delivery of MAC related information to and from the NIU, a dedicated Virtual Channel shall be utilised. The VPI,VCI for this channel shall be 0x000,0x0021.

- Upstream MAC messages:

AAL5 (as specified in Recommendation ITU-T I 363 ) adaptation shall be used to encapsulate each MAC PDU in an ATM cell. Upstream MAC information should be single 40 bytes cell messages.

- Downstream OOB MAC messages:

AAL5 (as specified in Recommendation ITU-T I 363 ) adaptation shall be used to encapsulate each MAC PDU in an ATM cell. Downstream OOB MAC information may be longer than 40 bytes.

- Downstream IB MAC messages:

Downstream IB MAC information is limited to 120 bytes long messages (A procedure to be able to send longer messages is under definition). No AAL5 layer is defined for MPEG-2 TS cells. MAC messages must therefore be sent as explained below:

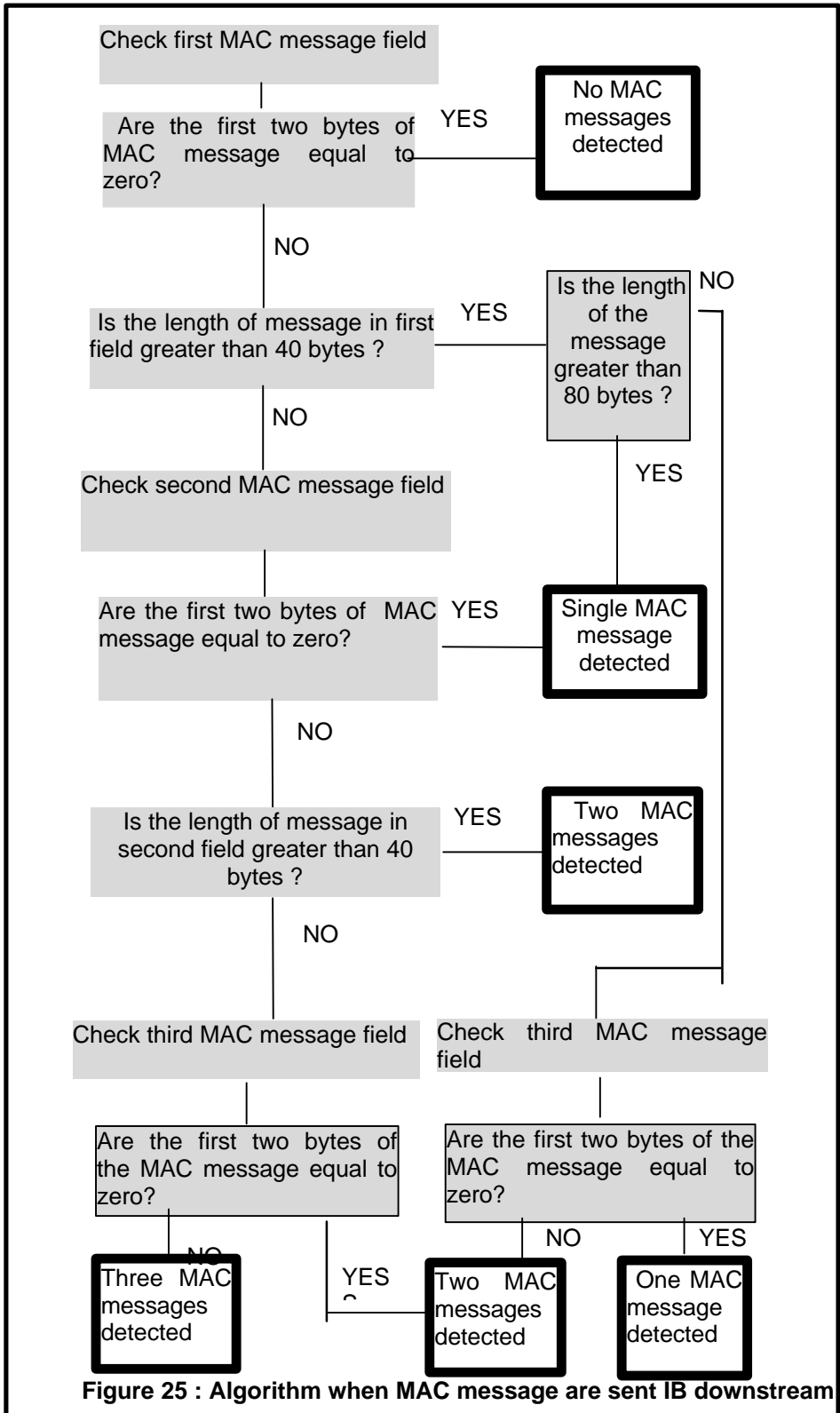

Figure 25 : Algorithm when MAC message are sent IB downstream

Since MAC related information is terminated at the NIU and INA a privately defined message structure will be utilised. The format of this message structure is illustrated below.

NOTE: All messages are sent most significant bit first.

NOTE: Message 0x23 is not used in the present release of the MAC protocol.

NOTE: When no MAC\_Address is specified in the message, it means that the message is sent broadcast. (Syntax\_indicator = 000)

**Table 16: MAC message structure**

| MAC_message() {                    | Bits        | Bytes      | Bit Number<br>Description |
|------------------------------------|-------------|------------|---------------------------|
| <b>Message_Configuration</b>       | <b>8</b>    | <b>1</b>   |                           |
| Protocol_Version                   | 5           |            |                           |
| Syntax_Indicator                   | 3           |            |                           |
| <b>Message_Type</b>                | <b>8</b>    | <b>1</b>   |                           |
| if (syntax_indicator==<br>001) {   |             |            |                           |
| <b>MAC_Address</b>                 | <b>(48)</b> | <b>(6)</b> |                           |
| }                                  |             |            |                           |
| {                                  |             |            |                           |
| <b>MAC_Information_Elements ()</b> |             | <b>N</b>   |                           |
| }                                  |             |            |                           |

### Protocol Version

Protocol\_Version is a 5-bit field used to identify the current MAC version. The value for this parameter is given in the following table.

**Table 17: Protocol\_version coding**

| Value | Definition                 |
|-------|----------------------------|
| 0     | DAVIC 1.0 Compliant device |
| 1     | DAVIC 1.1 Compliant device |
| 2-31  | Reserved                   |

### Syntax Indicator



Syntax\_Indicator is a 3-bit enumerated type that indicates the addressing type contained in the MAC message.

```
Enum Syntax_Indicator {No_MAC_Address ,MAC_Address_Included, reserved2..7};
```

**MAC Address**

MAC\_Address is a 48-bit value representing the unique MAC address of the NIU. This MAC address may be hard coded in the NIU or be provided by external source.

**<MAC> Reservation ID Response Message**

The <MAC> Reservation ID Response Message is used to acknowledge the receipt of the <MAC> Reservation\_ID\_Assignment message.

The format of the message is given below.

| Reservation_ID_Response_Message () { | Bits | Bytes | Bit Number / Description |
|--------------------------------------|------|-------|--------------------------|
| Connection_ID                        | 32   | 4     |                          |
| Reservation_ID                       | 16   | 2     |                          |
| }                                    |      |       |                          |

**Connection ID**

Connection\_ID is a 32-bit unsigned integer representing a global connection identifier for the NIU/STB Dynamic Connection.

**Reservation\_ID**

Reservation\_ID is a 16 bit unsigned number representing a locally assigned identifier for the connection. This is used as a short identifier by the NIU/STB to identify the appropriate Reservation\_Grant\_Messages.

**5.5.3 MAC Initialization and Provisioning**

This sub-clause defines the procedure for Initialisation and Provisioning that the MAC shall perform during power on or Reset.

- 1) Upon a NIU becoming active (i.e. powered up) , it must first find the current provisioning frequency. The NIU shall receive the **<MAC> Provisioning Channel Message**. This message shall be sent aperiodically on all downstream OOB channels when there are multiple channels. In the case of only a single channel, the message shall indicate the current channel is to be utilised for Provisioning. Upon receiving this message, the NIU shall tune to the Provisioning Channel.
- 2) After a valid lock indication on a Provisioning Channel, the NIU shall await the **<MAC> DEFAULT CONFIGURATION MESSAGE**. When received, the NIU shall configure its parameters as defined in the default configuration message. The Default Configuration Parameters shall include default timer values, default power levels, default retry counts as well as other information related to the operation of the MAC protocol.

The figure 25 shows the signaling sequence.

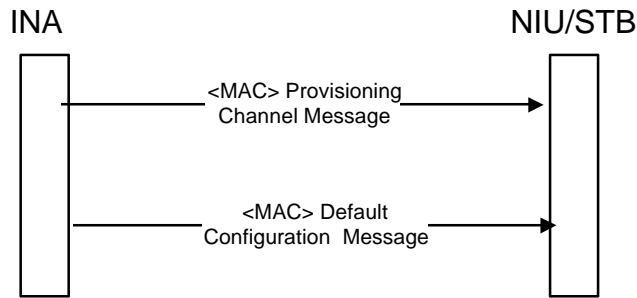

**Figure 26: Initialisation and Provisioning signalling**

### 5.5.3.1 <MAC> Provisioning Channel Message (Broadcast Downstream)

The <MAC> PROVISIONING CHANNEL MESSAGE is sent by the INA to direct the NIU to the proper Out-of-band frequency where provisioning is performed. The format of the message is shown in table 18.

**Table 18: Provisioning Channel Message Format**

| Provisioning_Channel_Message() {              | Bits | Bytes | Bit Number / Description |
|---|------|-------|--------------------------|
| <b>Provisioning_Channel_Control_Field</b>     | 8    | 1     |                          |
| <i>reserved</i>                               | 7    |       | 7-1:                     |
| provisioning_frequency_included               | 1    |       | 0: {no=0, yes=1}         |
| <i>if (provisioning_frequency_included) {</i> |      |       |                          |
| <b>Provisioning_Frequency</b>                 | (32) | (4)   |                          |
| <b>DownStream_Type</b>                        | 8    | 1     |                          |
|   |      |       |                          |
| }   |      |       |                          |
| }   |      |       |                          |

#### Provisioning Channel Control Field

Provisioning\_Channel\_Control\_Field is used to specify the downstream frequency where the NIU will be provisioned.

#### Provisioning Frequency Included

provisioning\_frequency\_included is a boolean when set, indicates that a downstream OOB frequency is specified that the NIU should tune to begin the provisioning process. When cleared, indicates that the current downstream frequency is the provisioning frequency.

## Provisioning Frequency

`Provisioning_Frequency` is a 32-bit unsigned integer representing the Out-of-band Frequency in which NIU provisioning occurs. The unit of measure is Hz.

## Downstream Type

`DownStream_Type` is an 8-bit enumerated type indicating the modulation format for the down stream connection. { reserved, QPSK\_1.544, QPSK\_3.088, 3..255 reserved}

### 5.5.3.2 <MAC> Default Configuration Message (Broadcast Downstream)

The <MAC> DEFAULT CONFIGURATION MESSAGE is sent by the INA to the NIU. The message provides default parameter and configuration information to the NIU. The format of the message is shown in table 19.

**Table 19: Default configuration message structure**

| Default_Configuration_Message(){               | Bits      | Bytes    | Bit Number / Description |
|--|-----------|----------|--------------------------|
| <b>Sign_On_Incr_Pwr_Retry_Count</b>            | <b>8</b>  | <b>1</b> |                          |
| <b>Service_Channel_Frequency</b>               | <b>32</b> | <b>4</b> |                          |
| <b>Service_Channel_Control_Field</b>           | <b>8</b>  | <b>1</b> |                          |
| MAC_Flag_Set                                   | 5         |          | 7-3                      |
| Service_Channel                                | 3         |          | 2-0                      |
| <b>Backup_Service_Channel_Frequency</b>        | <b>32</b> | <b>4</b> |                          |
| <b>Backup_Service_Channel_Control_Field</b>    | <b>8</b>  | <b>1</b> |                          |
| Backup_MAC_FlagSet                             | 5         |          | 7-3                      |
| Backup_Service_Channel                         | 3         |          | 2-0                      |
| <b>Service_Channel_Frame_Length [reserved]</b> | <b>16</b> | <b>2</b> | unused here              |
| <b>Service_Channel_Last_Slot</b>               | <b>16</b> | <b>2</b> |                          |
| <b>Max_Power_Level</b>                         | <b>8</b>  | <b>1</b> |                          |
| <b>Min_Power_Level</b>                         | <b>8</b>  | <b>1</b> |                          |
| <b>Upstream_Transmission_Rate</b>              | <b>3</b>  | <b>1</b> |                          |

### Sign-On Increment Power Retry Count

`Sign_On_Incr_Pwr_Retry_Count` is an 8-bit unsigned integer representing the number of attempts the NIU should try to enter the system at the same power level before incrementing its power level by steps of 0,5 dB.

### Service Channel Frequency

`Service_Channel_Frequency` is a 32-bit unsigned integer representing the upstream frequency assigned to the service channel. The unit of measure is in Hz. This channel is identified as channel #0 for collision indications.

`MAC_Flag_Set` is an 5 bit field representing the MAC Flag set assigned to the service channel. In the OOB downstream timing, the eight sets of flags are assigned the numbers 0..7. In the IB downstream timing, the 16 sets of flags are assigned the numbers 0..15. In the case of a 3.088 Mbit upstream channel, this parameter represents the first of two successively assigned flag sets. This flag set indicates the x value the channel x associated to Rxa, Rxb, Rxc in the reception indicator fields.

`Service_Channel` is a 3 bit field which defines the channel assigned to the `Service_Channel_Frequency`.

### Backup Service Channel Frequency

`Backup_Service_Channel_Frequency` is a 32-bit unsigned integer representing the upstream frequency assigned to the backup service channel. The backup service channel is used when entry on

the primary service channel fails. The unit of measure is in Hz. This channel is identified as channel #1 for collision indications.

`Backup_MAC_Flag_Set` is an 5 bit field representing the MAC Flag set assigned to the backup service channel. In the OOB downstream timing, the eight sets of flags are assigned the numbers 0..7. In the IB downstream timing, the 16 sets of flags are assigned the numbers 0..15. In the case of a 3.088 Mbit upstream channel, this parameter represents the first of two successively assigned flag sets.

`Backup_Service_Channel` is a 3 bit field which defines the channel assigned to the `Backup_Service_Channel_Frequency`.

#### **Service\_Channel\_Frame\_Length [reserved]**

Unused in this version.

#### **Service\_Channel\_Last\_Slot**

`Service_Channel_Last_Slot` is a 16-bit unsigned integer representing the last slot in the Service Channel frame that is used for contention based access. This number represents the largest slot value of the NIU slots counter ( $n \times 3 \times m$ , where  $n$  is defined in 5.4.3).

#### **Maximum Power Level**

`MAX_Power_Level` is a 8-bit unsigned integer representing the maximum power the NIU shall be allowed to use to transmit upstream. The unit of measure is in dBmicroV (RMS) on 75Ω.

#### **Minimum Power Level**

`MIN_Power_Level` is an 8-bit unsigned integer representing the minimum power the NIU shall be allowed to use to transmit upstream. The unit of measure is in dBmicroV (RMS) on 75Ω.

#### **Upstream Transmission Rate**

`Upstream_Transmission_Rate` is a 3-bit enumerated type that indicates the upstream transmission rate.

```
enum Upstream_Transmission_Rate {Upstream_256K, Upstream_1-544M, Upstream_3-088M, reserved3..7};
```

### **5.5.4 Sign On and Calibration**

The NIU shall Sign On via the Sign-On Procedure. The signalling flow for Sign-On is described below.

- The NIU shall tune to the downstream Provisioning channel and the upstream service channel with the information provided in the Initialisation and Provisioning sequence.
- The NIU shall await the **<MAC> Sign-On Message** from the INA Entity. The NIU shall utilise Contention based entry on the service channel to access the network.
- Upon receiving the **<MAC> Sign-On Message**, the NIU shall respond with the **<MAC> Sign-On Response Message**. The Sign-On Response Message shall be transmitted on a Ranging Control Slot.
- The INA, upon receiving the Sign-On Response Message shall validate the NIU and send the **<MAC> Ranging and Power Calibration Message**.
- The NIU shall respond to the **<MAC> Ranging and Power Calibration Message** with the **<MAC> Ranging and Power Calibration Response Message**. The **<MAC> Ranging and Power Calibration Response Message** shall be transmitted on a Ranging Control Slot.

- The INA shall send the **<MAC> Initialisation Complete Message** when the NIU is calibrated. The NIU is assumed to be calibrated if the message arrives within a window of 1.5 symbols (upstream rate) and a power within a window of 1.5 dB from their optimal value.

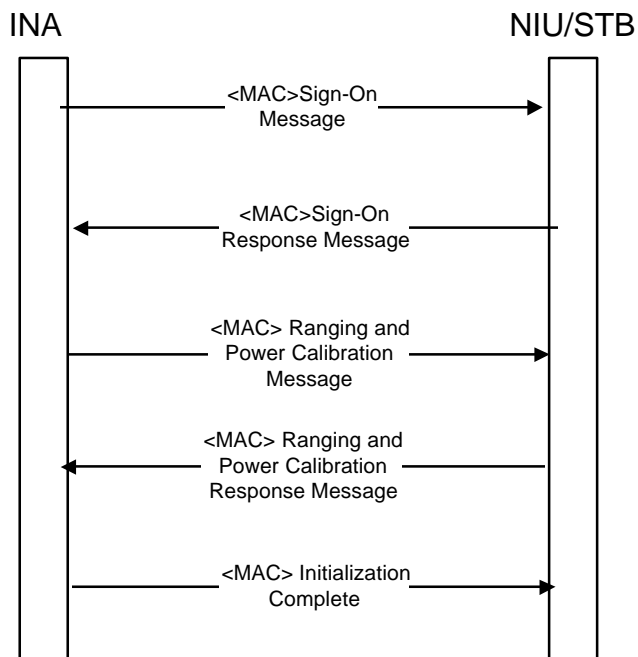

**Figure 27: Ranging and Calibration Signalling**

The figure 28 state diagram details the procedure described above:

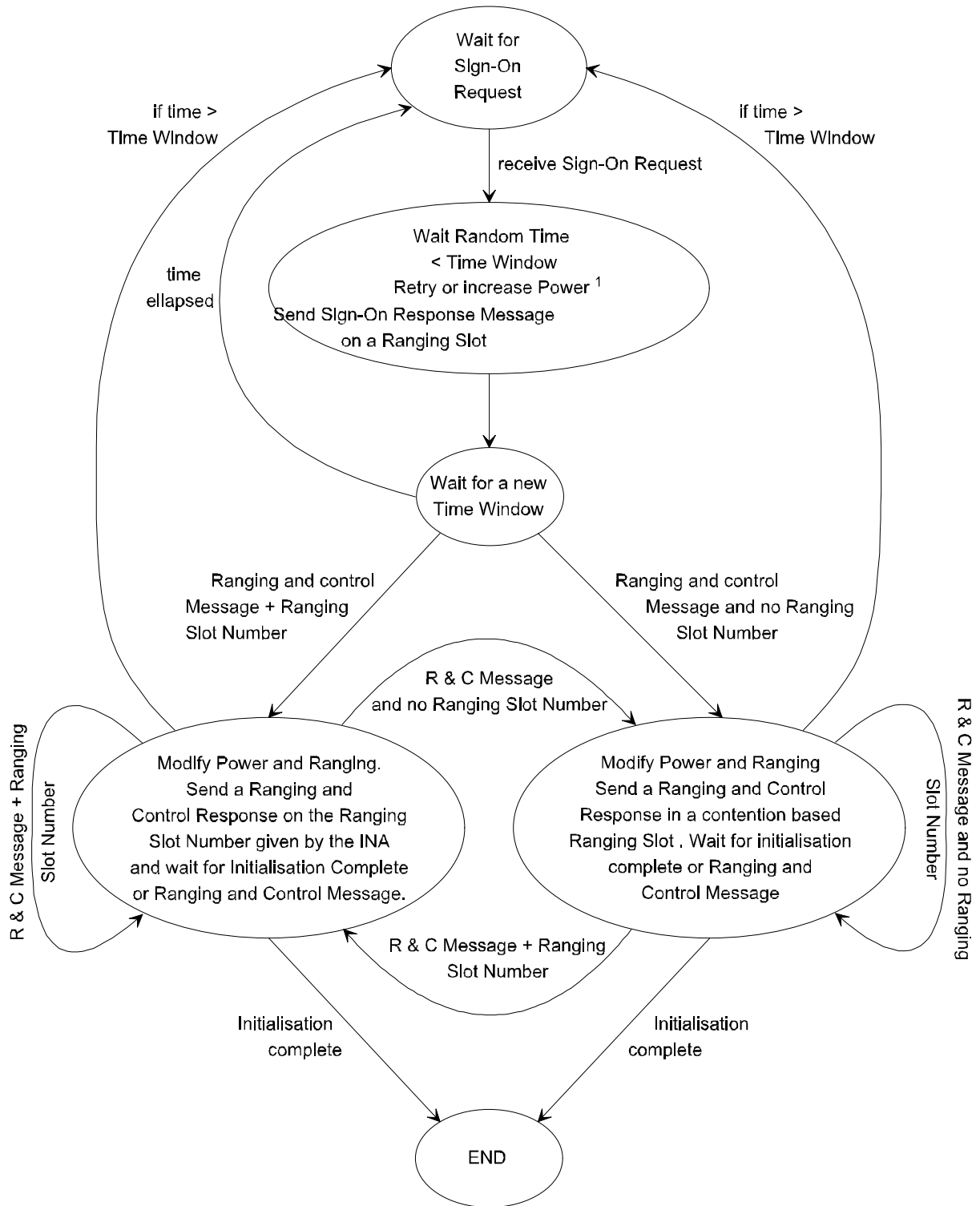

**Figure 28: State Diagram for Ranging and Calibration**

### 5.5.4.1 <MAC> Sign-On Request Message (Broadcast Downstream)

The <MAC> SIGN-ON REQUEST message is issued periodically by the INA to allow a NIU to indicate its presence in the network. The format of this subcommand is shown in table 20.

**Table 20: Sign-On Message structure**

| Sign-On_Request_Message(){   | Bits | Bytes | Bit Number / Description |
|--|------|-------|--------------------------|
| Sign-On_Control_Field  | 8    | 1     |                          |
| Reserved   | 7    |       | 7-1                      |
| Address_Filter_Params_Included   | 1    |       | 0 : {no,yes}             |
| <b>Response_Collection_Time_Window</b>                                       | 16   | 2     |                          |
| <i>if (Sign-On_Control_Field=</i><br><i>Address_Filter_Params_Included {</i> |      |       |                          |
| <b>Address_Position_Mask</b>   | (8)  | (1)   |                          |
| <b>Address_Comparison_Value</b>  | (8)  | (1)   |                          |
| <i>}</i>   |      |       |                          |
| }  |      |       |                          |

#### Sign-On Control Field

Sign-On\_Control\_Field specifies what parameters are included in the SIGN-ON REQUEST

#### Address Filter Parameters Included

address\_filter\_params\_included is a boolean, when set, indicates that the NIU should respond to the SIGN-ON REQUEST only if its address matches the filter requirements specified in the message.

#### Response Collection Time Window

Response\_Collection\_Time\_Window is a 16-bit unsigned integer that specifies the duration of time the NIU has to respond to the SIGN-ON REQUEST. The unit of measure is the millisecond (ms).

#### Address Position Mask

Address\_Position\_Mask is an 8-bit unsigned integer that indicates the bit positions in the NIU MAC address that are used for address filtering comparison. The bit positions are comprised between bit number  $2^{\text{Mask}}$  and  $2^{\text{Mask}}+7$ . Mask = 0 corresponds to the 8 LSBs of the address, i.e., it represents the number of bits shifted to the left. The maximum value is 40.

#### Address Comparison Value

Address\_Comparison\_Value is an 8-bit unsigned integer that specifies the value that the NIU should use for MAC address comparison.

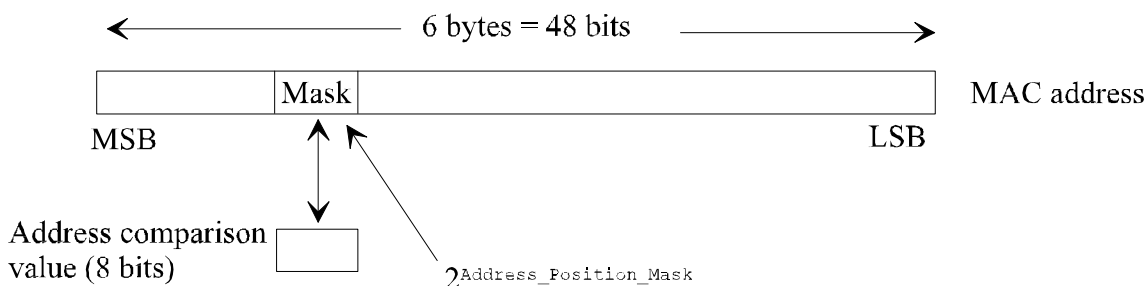

**Figure 29: Position of Mask in MAC address**

### 5.5.4.2 <MAC> Sign-On Response Message (Upstream Contention Ranging)

The <MAC> Sign-On Response Message is sent by the NIU in response to the <MAC> Sign-On Request Message issued by the INA Entity. The NIU shall wait for a random time less than `Response_Collection_Time_Window` to send this message.

**Table 21: Sign-On response Message structure**

| Sign-On_Response_Message(){ | Bits | Bytes | Bit Number / Description |
|-----------------------------|------|-------|--------------------------|
| [reserved]                  | 32   | 4     |                          |
| [reserved]                  | 16   | 2     |                          |
| Retry_Count                 | 8    | 1     |                          |
| }                           |      |       |                          |

#### Retry Count

`Retry_Count` is a 8-bit unsigned integer that indicates the number of transmissions of the <MAC> Sign-On Response. This field is always included in the response to the <MAC> Sign-On Request.

### 5.5.4.3 <MAC> Range and Power Calibration Message (Singlecast Downstream)

The <MAC> RANGE AND POWER CALIBRATION MESSAGE is sent by the INA to the NIU to adjust the power level or time offset the NIU is using for upstream transmission. The format of this message is shown in table 22.

**Table 22: Range and Power Calibration Message structure**

| Range_and_Power_Calibration_Message(){                               | Bits | Bytes | Bit Number / Description |
|--|------|-------|--------------------------|
| <b>Range Power Control Field</b>                                     | 8    | 1     |                          |
| <i>reserved</i>  | 5    |       | 7-3:                     |
| <i>ranging_slot_included</i>   | 1    |       | 2: {no, yes}             |
| <i>time_adjustment_included</i>                                      | 1    |       | 1: {no, yes}             |
| <i>power_ajustment_included</i>                                      | 1    |       | 0: {no, yes}             |
| <i>if (range_power_control_field == time_adjustment_included) {</i>  |      |       |                          |
| <b>Time_Offset_Value</b>   | (16) | (2)   |                          |
| <i>}</i>   |      |       |                          |
| <i>if (range_power_control_field == power_adjustment_included) {</i> |      |       |                          |
| <b>Power_Control_Setting</b>   | (8)  | (1)   |                          |
| <i>}</i>   |      |       |                          |
| <i>if (range_power_control_field == ranging_slot_included) {</i>     |      |       |                          |
| <b>Ranging_Slot_Number</b>   | (16) | (2)   |                          |
| <i>}</i>   |      |       |                          |

#### Range and Power Control Field

`Range_Power_Control_Field` specifies which Range and Power Control Parameters are included in the message.

#### Time Adjustment Included

`time_adjustment_included` is a boolean when set, indicates that a relative Time Offset Value is included that the NIU should use to adjust its upstream Fixed rate based reference.



## Power Adjust Included

`power_adjust_included` is a boolean when set, indicates that a relative Power Control Setting is included in the message

## Ranging Slot Included

`Ranging_Slot_Included` is a boolean when set, indicates the calibration slot available.

## Time Offset Value

`Time_Offset_Value` is a 16-bit short integer representing a relative offset of the upstream transmission timing. A negative value indicates an adjustment forward in time. A positive value indicates an adjustment back in time. The unit of measure is 100 ns (The NIU will adjust approximately its time offset to the closest value indicated by the `Time_Offset_Value` parameter, which implies that no extra clock is needed to adjust to the correct offset).

## Power Control Setting

`Power_Control_Setting` is an 8-bit signed integer to be used to set the new power level of the NIU. (A positive value represents an increase of the output power level)

$\text{New output\_power\_level} = \text{current output\_power\_level} + \text{power\_control\_setting} \times 0,5 \text{ dB}$

## Ranging Slot Number

`Ranging_Slot_Number` is a 16-bit unsigned integer that represents the reserved access Slot Number assigned for Ranging the NIU.

### 5.5.4.4 <MAC> Ranging and Power Calibration Response Message (Upstream reserved or contention Ranging)

The <MAC> RANGING AND POWER CALIBRATION RESPONSE Message is sent by the NIU to the INA in response to the <MAC> RANGING AND POWER CALIBRATION MESSAGE. The format of the message is shown in table 23.

**Table 23: Range Request Response Message Format**

| Ranging_Power_Response_Message(){ | Bits | Bytes | Bit Number / Description |
|-----------------------------------|------|-------|--------------------------|
| Power_Control_Setting             | 8    | 1     |                          |
| }                                 |      |       |                          |

## Power Control Setting

`Power_Control_Setting` is an 8-bit signed integer representing the upstream power level used by the NIU. It is a copy of the power control setting parameter received from INA.

### 5.5.4.5 <MAC> Initialization Complete Message (Singlecast Downstream)

This message has no message body. It indicates the end of the MAC Sign-On and Provisioning procedure.

## 5.5.5 Default Connection Establishment

Once a NIU has completed the Calibration State, it shall enter the Connection State. A low bit rate permanent connection is assigned to a NIU by the INA. After the initial calibration procedure, the INA provides a Default Connection to the NIU that the NIU shall utilise to communicate to the network. The message flow for such Connection Establishment is shown below.

- 1) After Initialisation, Provisioning and Sign On Procedures are complete, the INA shall assign a default upstream and downstream connection to the NIU. This connection can be assigned on any of the upstream channels except the upstream service channel ranging area. The INA shall assign the default connection by sending the **<MAC> Connect Message** to the NIU. This message shall contain the upstream connection parameters and downstream frequency on which the default connection is to reside.
- 2) The NIU, upon receiving the **<MAC> Connect Message** shall tune to the required upstream and downstream frequencies and send the **<MAC> Connect Response Message** confirming receipt of the message.
- 3) Upon receipt of the **<MAC> Connect Response Message**, the INA shall confirm the new connection to proceed by sending the **<MAC> Connect Confirm Message**.

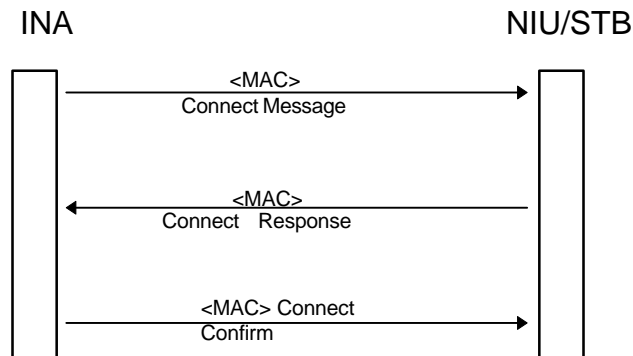

**Figure 30: Connection signalling**

5.5.5.1 <MAC> Connect Message (Singlecast Downstream)

Table 24: Connect Message Structure

| Connect_Message (){                              | Bits | Bytes | Bit Number/Description |
|--|------|-------|------------------------|
| <b>Connection_ID</b>                             | 32   | 4     |                        |
| <b>Session_Number</b>                            | 32   | 4     |                        |
| <b>Resource_Number</b>                           | 16   | 2     |                        |
| <b>Connection_Control_Field</b>                  | 8    | 1     |                        |
| Descriptor_Type                                  | 3    |       |                        |
| Upstream_Channel_Number                          | 3    |       |                        |
| MAC_Control_Parameters                           | 2    |       |                        |
| <b>Frame_Length</b>                              | (16) | (2)   |                        |
| <b>Maximum_Contention_Access_Message_Length</b>  | (8)  | (1)   |                        |
| <b>Maximum_Reservation_Access_Message_Length</b> | (8)  | (1)   |                        |
| if(Descriptor_Type == DS_ATM_CBD){               |      |       |                        |
| <b>Downstream_ATM_CBD()</b>                      | (64) | (8)   |                        |
| }  |      |       |                        |
| if(Descriptor_Type == DS_CBD_MPEG){              |      |       |                        |
| <b>Downstream_CBD_MPEG()</b>                     | (48) | (6)   |                        |
| }  |      |       |                        |
| if(Descriptor_Type == US_ATM_Included){          |      |       |                        |
| <b>Upstream_ATM_CBD()</b>                        | (64) | (8)   |                        |
| }  |      |       |                        |
| if(MAC_Control_Params == slot_list_assignment){  |      |       | Fixed Rate Access      |
| <b>Number_Slots_Defined</b>                      | (8)  | (1)   |                        |
| for (i=0;i<Number_Slots_Assigned; i++){          |      |       |                        |
| <b>Slot_Number</b>                               | (16) | (2)   |                        |
| }  |      |       |                        |
| }  |      |       |                        |
| if (MAC_Control_Params == cyclic_Assignment){    |      |       | Fixed Rate Access      |
| <b>Fixedrate_Start</b>                           | (16) | (2)   |                        |
| <b>Fixedrate_Dist</b>                            | (16) | (2)   |                        |
| <b>Fixedrate_End</b>                             | (16) | (2)   |                        |
| }  |      |       |                        |

**Connection ID**

Connection\_ID is a 32-bit unsigned integer representing a connection Identifier for the NIU Dynamic Connection.

**Session Number**

Session\_Number is a 32-bit unsigned integer representing the Session that the connection parameters are associated.

**Resource Number**

Resource\_Number is a 16-bit unsigned integer providing a unique number to the resource defined in the message.

## Connection Control Field

Connection\_Control\_Field is an 8-bit unsigned integer that defines parameters and control for Descriptor\_Type, Upstream\_Channel\_Number and MAC\_Control\_Parameters. This is partitioned across the 8-bits as shown below.

**Table 25: Connection Control Field substructure**

| Bit 7           | 6 | 5 | 4                       | 3 | 2 | 1               | 0 |
|-----------------|---|---|-------------------------|---|---|-----------------|---|
| Descriptor_Type |   |   | Upstream_Channel_Number |   |   | MAC_Ctrl_Params |   |

### 54400.1 Descriptor Type

Descriptor\_Type is a 3-bit unsigned integer that represents the connection descriptors present within the message. The values are defined in table 26.

**Table 26: Descriptor Type substructure**

| Bit Number | Definition   |
|------------|--|
| 7          | When set indicates that upstream ATM Descriptor is present in the message    |
| 6          | When set indicates that downstream MPEG Descriptor is present in the message |
| 5          | When set indicates that downstream ATM Descriptor is present in the message. |

### 54400.1 Upstream Channel Number

Upstream\_Channel\_Number is a 3-bit unsigned integer that provides an identifier for the upstream channel.

### 54400.1 MAC Control Parameters

MAC\_Control\_Parameters is a 2-bit unsigned integer that indicates the type of upstream resources assigned in the connection.

**Table 27: Control Parameter substructure**

| MAC_Control_Parameters | Definition                             |
|------------------------|--|
| 10                     | indicates a slot list is included      |
| 01                     | indicates a cyclical assignment        |
| 00                     | indicates contention based access only |
| 11                     | [Reserved]                             |

## Frame Length

Frame\_length - This 16-bit unsigned number represents the number of successive slots in the contentionless access region that associated with each contentionless slot assignment. In the slot\_list method of allocating slots it represents the number of successive slots associated with each element in the list. In the cyclic method of allocating slots it represents the number of successive slots associated with the Fixedrate\_Start\_slot and those which are multiples of Fixedrate\_Distance from the Fixedrate\_Start\_slot within the Fixed rate access region.

## Maximum Contention Access Message Length

Maximum\_contention\_access\_message\_length is an 8-bit number representing the maximum length of a message in ATM sized cells that may be transmitted using contention access. Any message greater than this should use reservation access.

## Maximum Reservation Access Message Length

Maximum\_reservation\_access\_message\_length is an 8-bit number representing the maximum length of a message in ATM sized cells that may be transmitted using a single reservation access. Any message greater than this should be transmitted by making multiple reservation requests.

## Downstream ATM Connection Block Descriptor

**Table 28: ATM Connection Block Descriptor substructure**

| Downstream_ATM_CBD() {      | Bits | Bytes | Bit Number /<br>Description |
|-----------------------------|------|-------|-----------------------------|
| <b>Downstream_Frequency</b> | 32   | 4     |                             |
| <b>Downstream_VPI</b>       | 8    | 1     |                             |
| <b>Downstream_VCI</b>       | 16   | 2     |                             |
| <b>Downstream_Type</b>      | 8    | 1     |                             |
| }                           |      |       |                             |

### 54402.1 Downstream Frequency

Downstream\_Frequency is a 32-bit unsigned integer representing the Frequency where the connection resides. The unit of measure is in Hz.

### 54402.1 Downstream Virtual Path Identifier

Downstream\_VPI is an 8-bit unsigned integer representing the ATM Virtual Path Identifier that is used for downstream transmission over the Dynamic Connection.

### 54402.1 Downstream Virtual Channel Identifier

Downstream\_VCI is an 16-bit unsigned integer representing the ATM Virtual Channel Identifier that is used for downstream transmission over the Dynamic Connection.

### 54402.1 DownStream\_Type

DownStream\_Type is an 8-bit enumerated type indicating the modulation format for the down stream connection. { QAM, QPSK\_1.544, QPSK\_3.088, 3..255 reserved}

## Downstream MPEG Connection Block Descriptor

**Table 29: Downstream\_CBD\_MPEG substructure**

| Downstream_CBD_MPEG() {     | Bits | Bytes | Bit Number /<br>Description |
|-----------------------------|------|-------|-----------------------------|
| <b>Downstream_Frequency</b> | 32   | 4     |                             |
| <b>Program Number</b>       | 16   | 2     |                             |
| }                           |      |       |                             |

### 54402.1 Downstream Frequency

`Downstream_Frequency` is a 32-bit unsigned integer representing the Frequency where the connection resides. The unit of measure is in Hz.

### 54402.1 Program Number

`Program_Number` is a 16-bit unsigned integer uniquely referencing the downstream virtual connection assignment.

## Upstream ATM Connection Block Descriptor

**Table 30: Upstream\_CBD substructure**

| Upstream_ATM_CBD          | Bits | Bytes | Bit Number /<br>Description |
|---------------------------|------|-------|-----------------------------|
| <b>Upstream_Frequency</b> | 32   | 4     |                             |
| <b>Upstream_VPI</b>       | 8    | 1     |                             |
| <b>Upstream_VCI</b>       | 16   | 2     |                             |
| <b>MAC_Flag_Set</b>       | 5    | 1     | 7:3                         |
| <b>Upstream_Rate</b>      | 3    |       | 2:0                         |
|                           |      |       |                             |
| }                         |      |       |                             |

### 54402.1 Upstream Frequency

`Upstream_Frequency` is a 32-bit unsigned integer representing the channel on assigned to the connection. The unit of measure is in Hz.

### 54402.2 Upstream Virtual Path Identifier

`Upstream_VPI` is an 8-bit unsigned integer representing the ATM Virtual Path Identifier that is used for upstream transmission over the Dynamic Connection.

### 54402.3 Upstream Virtual Channel Identifier

`Upstream_VCI` is an 16-bit unsigned integer representing the ATM Virtual Channel Identifier that is used for upstream transmission over the Dynamic Connection.

### 54402.4 MAC\_Flag\_Set

MAC\_Flag\_Set is an 5 bit field representing the MAC Flag set assigned to the connection. In the OOB downstream timing, the eight sets of flags are assigned the numbers 0..7. In the IB downstream timing, the 16 sets of flags are assigned the numbers 0..15. In the case of a 3.088 Mbit upstream channel, this parameter represents the first of two successively assigned flag sets.

#### 54402.4 Upstream\_Rate

Upstream\_Rate is an 3-bit enumerated type indicating the data rate for the upstream connection. { Upstream\_256K, Upstream\_1.544M, Upstream\_3.088M, 3..7 reserved}

#### Number of Slots Defined

Number\_Slots\_Defined is an 8-bit unsigned integer that represents the number of slot assignments contained in the message. The unit of measure is slots.

#### Slot Number

Slot\_Number is a 16-bit unsigned integer that represents the Fixed rate based Slot Number assigned to the NIU.

#### Fixed rate Start

Fixedrate\_Start - This 16-bit unsigned number represents the starting slot within the fixed rate access region that is assigned to the NIU. The NIU may use the next Frame\_length slots of the fixed rate access regions.

#### Fixed rate Distance

Fixedrate\_Distance - This 16-bit unsigned number represents the distance in slots between additional slots assigned to the NIU. The NIU is assigned all slots that are a multiple of Fixedrate\_Distance from the Fixedrate\_Start\_slot which don't exceed Fixedrate\_End\_slot The NIU may use the next Frame\_length slots of the fixed rate access regions from each of these additional slots.

#### Fixed rate End

Fixedrate\_End - This 16-bit unsigned number indicates the last slot that may be used for fixed rate access. The slots assigned to the NIU, as determined by using the Fixedrate\_Start\_slot and Fixedrate\_Distance, cannot exceed this number.

#### 5.5.5.2 <MAC> Connect Response (Upstream contention, reserved or fixed rate access)

The <MAC> CONNECT RESPONSE MESSAGE is sent to the INA from the NIU in response to the <MAC> CONNECT MESSAGE. The message shall be transmitted on the upstream frequency specified in the <MAC> CONNECT MESSAGE.

**Table 31: Connect response message structure**

| Connect_Response() { | Bits | Bytes | Bit Number / Description |
|----------------------|------|-------|--------------------------|
| <b>Connection_ID</b> | 32   | 4     |                          |
| }                    |      |       |                          |

#### Connection ID

Connection\_ID is a 32-bit unsigned integer representing a global connection Identifier for the NIU Dynamic Connection.

### 5.5.5.3 <MAC> Connect Confirm (Singlecast Downstream)

The <MAC> Connect Confirm message is sent from the INA to the NIU. Its usage is recommended when INA validation of new connection is required.

**Table 32: Connect Confirm message structure**

| Connect_Confirm(){ | Bits | Bytes | Bit Number /<br>Description |
|--------------------|------|-------|-----------------------------|
| Connection_ID      | 32   | 4     |                             |
| }                  |      |       |                             |

#### Connection ID

Connection\_ID is a 32-bit unsigned integer representing a global connection Identifier for the NIU Dynamic Connection.

### 5.5.6 Data connections

A connection is initiated by the INA using the <MAC> Connect Message explained in subclause 5.5.5.1. This message is either used to immediately assign time slots for a fixed rate connection or just to assign a connection ID and related parameters without time slot assignment. In particular, for reservation or contention access, no time slots are assigned in the Connect Message, but the connection ID shall be used in requests for slots by the NIU.

#### Connection Assignment

The INA can assign other connections by using the <MAC> Connect message described previously. The NIU cannot request a connection, it must be initiated by higher layers.

#### Connection Release

This subclause defines the MAC signaling requirements for connection release. The figure below displays the signaling flow for releasing a connection. The NIU cannot release a connection, this must be initiated by higher layers. This message is thus initiated by the INA only.

- 1) Upon receiving the <MAC> Release Message from the INA, the NIU shall teardown the upstream connection established for the particular .
- 2) Upon teardown of the upstream connection, the NIU shall send the <MAC> Release Response Message on the default upstream channel.

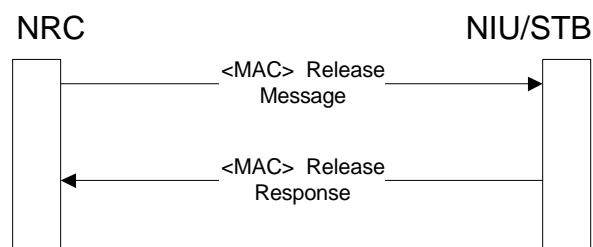

**Figure 31: Connection release signalling**

#### <MAC> Release Message (Singlecast Downstream)

The <MAC> Release Message is sent from the INA to the NIU to terminate a previously established connection.



**Table 33: Release Message Structure**

| Release_Message() {                   | Bits | Bytes | Bit Number /<br>Description |
|---------------------------------------|------|-------|-----------------------------|
| <b>Number_of_Connections</b>          | 8    | 1     |                             |
| for(i=0;i<Number_of_Connections;i++){ |      |       |                             |
| <b>Connection_ID</b><br>}             | 32   | 4     |                             |
| }                                     |      |       |                             |

*54500.1 Connection ID*

Connection\_ID is a 32-bit unsigned integer representing a global connection Identifier for the NIU Dynamic Connection.

**<MAC> Release Response (Upstream contention, reserved or fixed rate)**

The <MAC> RELEASE RESPONSE MESSAGE is sent by the NIU to the INA to acknowledge the release of a connection. The format of the message is shown in table 34.

**Table 34: Release Response Message structure**

| Release_Response_Message () { | Bits | Bytes | Bit Number /<br>Description |
|-------------------------------|------|-------|-----------------------------|
| <b>Connection_ID</b>          | 32   | 4     |                             |
| }                             |      |       |                             |

*54500.1 Connection ID*

Connection\_ID is a 32-bit unsigned integer representing the global connection Identifier used by the NIU for this connection.

**5.5.6.1 Fixed Rate Access**

Fixed rate access is provided by the INA using the <MAC> Connect Message.

**5.5.6.2 Contention Based Access**

The NIU shall use contention based slots specified by the slot boundary definition fields (Rx) to transmit contention based messages (see sub-clause 5.3). The format of contention based MAC messages is described by the MAC message format (see sub-clause 5.5.2.3).

**5.5.6.3 Reservation Access**

This sub-clause defines the MAC signalling requirements for reservation access. The figure below displays the signalling flow for reserving an access.

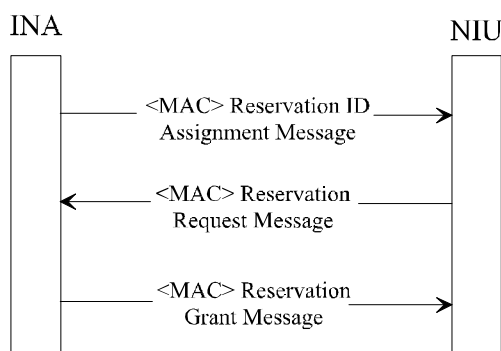

**Figure 32: Reservation access signalling**

- 1) The NIU shall wait for a <MAC> Reservation ID Assignment Message from the INA before it can request reservation access.
- 2) At any time when needed after receiving the reservation ID, the NIU can request a certain number of slots to the INA using the <MAC> Reservation Request Message.
- 3) The INA shall respond to that message using the <MAC> Reservation Grant Message.
- 4). If the NIU has not received the <MAC> Reservation Grant Message before the Grant\_Protocol\_Timeout, it shall send a <MAC> Reservation Status Request to the INA. This leads back to 3.

**<MAC> Reservation ID Assignment Message (Singlecast Downstream)**

The <MAC> Reservation ID Assignment Message is used to assign the NIU a Reservation\_ID. The NIU identifies its entry in the Reservation\_grant\_message by comparing the Reservation\_ID assigned to it by the Reservation\_ID\_assignment\_message and the entries in the Reservation\_Grant\_message.

The format of the message is given in table 35.

**Table 35: Reservation ID assignment message structure**

| Reservation_ID_assignment_Message () { | Bits | Bytes | Bit Number / Description |
|--|------|-------|--------------------------|
| <b>Connection_ID</b>                   | 32   | 4     |                          |
| <b>Reservation_ID</b>                  | 16   | 2     |                          |
| <b>Grant_protocol_timeout</b>          | 16   | 2     |                          |
| }                                      |      |       |                          |

**54520.1 Connection ID**

Connection\_ID is a 32-bit unsigned integer representing a global connection identifier for the NIU Dynamic Connection.

**54520.1 Reservation\_ID**

Reservation\_ID is a 16-bit unsigned number representing a locally assigned identifier for the connection. This is used as a short identifier by the NIU to identify the appropriate Reservation\_Grant\_Messages.

**54520.1 Grant\_protocol\_timeout**

`Grant_protocol_timeout` is a 16-bit unsigned number representing the time in milliseconds that the NIU should wait before verifying the status of pending grants. This parameter specifies the time that the NIU should wait after receiving the last `Reservation_grant_message`, with an entry addressed to the NIU, before initiating a reservation status request. If the NIU has pending grants and the timeout occurs, it should send the `Reservation_status_request` message to the INA. The INA will respond with the `Reservation_grant_message` (probably without granting any slots) to inform the NIU of any remaining slots left to be granted. This allows the NIU to correct any problems should they exist such as issuing an additional request for slots or waiting patiently for additional grants.

**<MAC> Reservation Request Message (Upstream contention, fixed rate or reserved)**

**Table 36: Reservation Request Message structure**

| <code>Reservation_Request_message () {</code>   | Bits | Bytes | Bit Number /<br>Description |
|---|------|-------|-----------------------------|
| <code>    Reservation_ID</code>                 | 16   | 2     |                             |
| <code>    Reservation_request_slot_count</code> | 8    | 1     |                             |
| <code>}</code>                                  |      |       |                             |

This message is sent from the NIU to the INA.

*54520.1 Reservation\_ID*

`Reservation_ID` is a 16-bit unsigned number representing a locally assigned identifier for the connection. This is used as a short identifier by the NIU to identify the appropriate `Reservation_Grant_Messages`.

*54520.1 Reservation Request Slot Count*

`Reservation_request_slot_count` is an 8-bit unsigned number representing the number of slots requested by the NIU. This is the number of sequential slots that will be allocated in the reservation region of the upstream channel. The INA will respond with the `Reservation_Grant` message granting the request.

**<MAC> Reservation Grant Message (Broadcast Downstream)**

The <MAC> RESERVATION GRANT MESSAGE is used to indicate to the NIU which slots have been allocated in response to the Reservation Request message. The NIU identifies its entry in the `Reservation_grant_message` by comparing the `Reservation_ID` assigned to it by the `Reservation_ID_assignment_message` and the entries in the `Reservation_Grant_message`.

The format of the message is given in table 37.

**Table 37: Reservation Grant Message structure**

| Reservation_grant_message () {    | Bits | Bit Number/<br>Description |
|-----------------------------------|------|----------------------------|
| <b>Reference_slot</b>             | 16   |                            |
| <b>Number_grants</b>              | 8    |                            |
| for (I=1; I<=Number_grants; I++){ |      |                            |
| <b>Reservation_ID</b>             | 16   |                            |
| <b>Grant_slot_count</b>           | 4    |                            |
| <b>Remaining_slot_count</b>       | 5    |                            |
| <b>Grant_control</b>              | 2    |                            |
| <b>Grant_slot_offset</b>          | 5    |                            |
| }                                 |      |                            |
| }                                 |      |                            |

*54520.1 Reference\_slot*

Reference\_slot is an 16-bit unsigned number indicating the reference point for the remaining parameters of this message. This represents a physical slot of the upstream channel. Since the upstream and downstream slots are not aligned, the INA shall send this message in a downstream slot such that it is received by the NIU before the Reference\_slot exists on the upstream channel.

*54520.1 Number\_grants*

Number\_grants is an 8-bit unsigned number representing the number of grants contained within this message.

*54520.1 Reservation\_ID*

Reservation\_ID is a 16-bit unsigned number representing a locally assigned identifier for the connection. This is used as a short identifier by the NIU to identify the appropriate Reservation\_Grant\_Messages.

*54520.1 Grant\_slot\_count*

Grant\_slot\_count is an 4-bit unsigned number representing the number of sequential slots currently granted for the upstream burst. Upon receipt of this message the NIU is assigned Grant\_slot\_count sequential slots in the reservation access region of the upstream channel starting at the position indicated by the Reference\_slot and Grant\_slot\_offset values. A value of zero indicates that no slots are being granted. This would typically be the case in a response to a Reservation\_status\_request message

*54520.1 Remaining\_slot\_count*

Remaining\_slot\_count is a 5-bit unsigned number representing the remaining slots to be granted by the INA with subsequent grant messages. A value of 0x1f indicates that 31 or more slots will be made available in the future. A value of 0x0 indicates that no additional slots will be granted in the future and that the slots granted in this message represent the only remaining slots available for the connection. The NIU should monitor this count to determine if sufficient slots remain to satisfy current needs. Should additional slots be required because of lost grant messages or additional demand, additional slots should be requested using the Reservation\_request\_message. Additional Reservation\_request\_messages shall be sent only when the Remaining\_slot\_count is less than 15. To minimise contention on the upstream channel, the Reservation\_request\_message may be sent in one of the slots granted by the Reservation\_grant\_message.

### 54520.1 Grant\_slot\_offset

Grant\_slot\_offset is a 5-bit unsigned number representing the starting slot to be used for the upstream burst. This number is added to the Reference slot to determine the actual physical slot. Upon receipt of this message the NIU is assigned Grant\_slot\_count sequential slots in the reservation access region of the upstream channel.

### <MAC> Reservation Status Request (Upstream contention, fixed rate or reserved)

The <MAC> RESERVATION STATUS REQUEST Message is used to determine the status of the outstanding grants to be assigned by the INA. This message is only sent after the Grant protocol time-out is exceeded. The INA will respond with the Reservation\_grant\_message (possibly without granting any slots) to inform the NIU of any remaining slots left to be granted. This allows the NIU to correct any problems should they exist such as issuing an additional request for slots or waiting patiently for additional grants.

The format of the message is given in table 38.

**Table 38: Reservation status request message structure**

| Reservation_Status_Request_Message () { | Bits | Bytes | Bit Number / Description |
|---|------|-------|--------------------------|
| Reservation_ID                          | 16   | 2     |                          |
| Remaining_request_slot_count            | 8    | 1     |                          |
| }                                       |      |       |                          |

### 54520.1 Reservation\_ID

Reservation\_ID is a 16-bit unsigned number representing a locally assigned identifier for the connection. This is used as a short identifier by the NIU to identify the appropriate Reservation\_Grant\_Messages.

### 54520.1 Remaining\_request\_slot\_count

Remaining\_request\_slot\_count is an 8-bit unsigned number representing the number of slots that the NIU is expecting to be granted.

## 5.5.7 MAC Link Management

The MAC Link Management tasks provide continuous monitoring and optimisation of upstream resources. These functions include:

- Power and Timing Management
- Fixed rate Allocation Management
- Channel Error Management

### 5.5.7.1 Power and Timing Management

Power and Timing Management shall provide continuous monitoring of upstream transmission from the NIU. The <MAC> Ranging and Power Calibration Message is used to maintain a NIU within predefined thresholds of power and time.

The Upstream Burst Demodulator shall continuously monitor the upstream burst transmissions from an NIU. Upon detection of an NIU outside the predefined range, the INA shall send the <MAC> Ranging and Power Calibration Message to the NIU.

### 5.5.7.2 TDMA Allocation Management

To ensure optimum assignment of TDMA resources, the INA shall ensure the upstream allocation of TDMA resources for various connections remain intact when allocating resources to a new connection. However, in the event that reconfiguration is required to minimise fragmentation of resources, then the INA shall dynamically reconfigure the upstream TDMA assignments to a NIU or group of NIUs. The **<MAC> Reprovision Message** is utilised to change previously established connection parameters.

#### **<MAC> Reprovision Message (Singlecast Downstream)**

The <MAC> REPROVISION MESSAGE is sent by the INA to the NIU to reassign upstream resources (maintaining the originally requested QoS parameters at the establishment of the connection.) This message is intended for Fixed rate based channel maintenance by the INA to redistribute or reassign resources allocated to a NIU.

**Table 39: Reprovision Message structure**

| Reprovision_Message (){   | Bits | Bytes | Bit Number / Description         |
|---|------|-------|----------------------------------|
| <b>Reprovision_Control_Field</b>  | 8    | 1     |                                  |
| <i>Reserved</i>   | 2    |       | 7-6                              |
| New_Downstream_IB_Frequency   | 1    |       | 5 :<br>{no,yes}                  |
| New_Downstream_OOB_Frequency  | 1    |       | 4 :<br>{no,yes}                  |
| New_Upstream_Frequency_Included   | 1    |       | 3 :<br>{no,yes}                  |
| New_Frame_Length_Included   | 1    |       | 2 :<br>{no,yes}                  |
| New_Cyclical_Assignment_Included  | 1    |       | 1 :<br>{no,yes}                  |
| New_Slot_List_Included  | 1    |       | 0 :<br>{no,yes}                  |
| <i>if (Reprovision_Control_Field=<br/>New_Downstream_OOB_Frequency)</i> |      |       |                                  |
| <b>New_Downstream_IB_Frequency</b>                                      | (32) | (4)   |                                  |
| <i>if (Reprovision_Control_Field=<br/>New_Downstream_OOB_Frequency)</i> |      |       |                                  |
| <b>New_Downstream_OOB_Frequency</b>                                     | (32) | (4)   |                                  |
| <b>DownStream_Type</b>  | 8    | 1     |                                  |
| <b>New_Downstream_OOB_Frequency</b>                                     | (32) | (4)   |                                  |
| <i>if (Reprovision_Control_Field=<br/>New_Frequency_Included)</i>       |      |       |                                  |
| <b>New_Upstream_Frequency</b>   | (32) | (4)   |                                  |
| <b>New_Upstream_Channel_Number</b>                                      | 3    | 1     | 7:5                              |
| <b>reserved</b>   | 2    |       | 4:3                              |
| <b>Upstream_Rate</b>  | 3    |       | 2:0                              |
| <b>MAC_Flag_Set</b>   | 5    | 1     | 7:3                              |
| <b>Reserved</b>   | 3    |       | 2:0                              |
| <b>New_Upstream_Frequency</b>   | (32) | (4)   |                                  |
| <i>if (Connection_Control_Field=<br/>New_Frame_Size_Included)</i>       |      |       |                                  |
| <b>New_Frame_Length</b>   | (16) | (2)   | 9-0 :<br>Unsigned                |
| <i>if (Reprovision_Control_Field=<br/>New_Slot_List){</i>               |      |       |                                  |
| <b>Number_of_Connections</b>  | (8)  | (1)   |                                  |
| <i>for(i=0;i&lt;Number_of_Connections;i++){</i>                         |      |       |                                  |
| <b>Connection_ID</b>  | (32) | (1)   |                                  |
| <i>if(Reprovision_Control_Field ==<br/>new_slot_list_included){</i>     |      |       | <b>Fixed<br/>Rate<br/>Access</b> |
| <b>Number_Slots_Defined</b>   | (8)  | (1)   |                                  |
| <i>for(i=0;j&lt;Number_Slots_Assigned;i++){</i>                         |      |       |                                  |
| <b>Slot_Number</b>  | (16) | (2)   |                                  |
| <i>}</i>  |      |       |                                  |

|  |      |     |                                  |
|--|------|-----|----------------------------------|
| <i>if (Reprovision_Control_Field ==<br/>new_cyclic_Assignment_included){</i> |      |     | <b>Fixed<br/>Rate<br/>Access</b> |
| <b>Fixedrate_Start</b>   | (16) | (2) |                                  |
| <b>Fixedrate_Dist</b>  | (16) | (2) |                                  |
| <b>Fixedrate_End</b>   | (16) | (2) |                                  |
| <i>}</i>   |      |     |                                  |

#### 54610.1 Reprovision Control Field

Reprovision\_Control\_Field specifies what modifications to upstream resources are included.

#### 54610.2 New Downstream OOB Frequency

New\_Upstream\_OOB\_Frequency is a boolean that indicates that a new downstream OOB frequency is specified in the message

#### 54610.3 New Downstream IB Frequency

New\_Upstream\_IB\_Frequency is a boolean that indicates that a new downstream IB frequency is specified in the message

#### 54610.4 New Upstream Frequency Included

New\_Upstream\_Frequency\_Include is a boolean that indicates that a new upstream frequency is specified in the message.

#### 54610.5 New Frame Length Included

New\_Frame\_Length\_Include is a boolean that indicates that a new upstream frame is specified in the message.

#### 54610.6 New Slot List Included

New\_Slot\_List\_Include is a boolean that indicates that a new slot list is specified in the message.

#### 54610.7 New Cyclical Assignment Included

New\_Cyclical\_Assignment\_Include is a boolean that indicates that a new cyclical assignment is specified in the message.

#### 54610.8 New Downstream IB Frequency

New\_Downstream\_IB\_Frequency is a 32-bit unsigned integer representing the reassigned downstream IB carrier center frequency. The unit of measure is Hz.

#### 54610.9 New Downstream OOB Frequency

New\_Downstream\_OOB\_Frequency is a 32-bit unsigned integer representing the reassigned downstream OOB carrier center frequency. The unit of measure is Hz.

DownStream\_Type is an 8-bit enumerated type indicating the modulation format for the down stream connection. { reserved, QPSK\_1.544, QPSK\_3.088, 3..255 reserved}

#### 54610.10 New Upstream Frequency

New\_Upstream\_Frequency is a 32-bit unsigned integer representing the reassigned upstream carrier center frequency. The unit of measure is Hz.



UpstreamStream\_Rate is a 3-bit enumerated type indicating the data rate for the upstream connection. { Upstream\_256K, Upstream\_1.544M, Upstream\_3.088M, 3..7 reserved}

MAC\_Flag\_Set is a 5-bit field representing the MAC Flag set assigned to the connection. In the OOB downstream timing, the eight sets of flags are assigned the numbers 0..7. In the IB downstream timing, the 16 sets of flags are assigned the numbers 0..15. In the case of a 3.088 Mbit upstream channel, this parameter represents the first of two successively assigned flag sets.

*54610.11 New Frame Length*

New\_Frame\_Length is a 16-bit unsigned integer representing the size of the reassigned upstream Fixed rate based frame. The unit of measure is in slots.

*54610.12 Number of Slots Defined*

Number\_Slots\_Defined is an 8-bit unsigned integer that represents the number of slot assignments contained in the message. The unit of measure is slots.

*54610.13 Slot Number*

Slot\_Number is a 16-bit unsigned integer that represents the Fixed rate based Slot Number assigned to the Network Interface Unit.

**5.5.7.3 Channel Error Management**

During periods of connection inactivity, the NIU shall enter an Idle Mode. Idle mode is characterised by periodic transmission by the NIU of a **<MAC> Idle Message**. The Idle Mode transmission shall occur at a periodic rate sufficient for the INA to establish Packet Error Rate statistics.

**<MAC> Idle Message (Upstream fixed rate or reserved)**

The **<MAC> Idle Message** is sent by the NIU within the STB to the INA at predefined intervals (between 1 and 10 minutes) when upstream connection buffers are empty.

**Table 40: Idle Message structure**

| Idle_Message() {             | Bits | Bytes | Bit Number / Description |
|------------------------------|------|-------|--------------------------|
| <b>Idle_Sequence_Count</b>   | 8    | 1     |                          |
| <b>Power_Control_Setting</b> | 8    | 1     |                          |
| }                            |      |       |                          |

*54620.1 Idle Sequence Count*

Idle\_Sequence\_Count is a 8-bit unsigned integer representing the count of <MAC> IDLE MESSAGES transmitted while the NIU is Idle.

*54620.2 Power Control Setting*

Power\_Control\_Setting is a 8-bit unsigned integer representing the absolute power attenuation that the NIU is using for upstream transmission.

**5.5.7.4 Link Management Messages**

**<MAC> Transmission Control Message (Singlecast or Broadcast Downstream)**

The <MAC> TRANSMISSION CONTROL MESSAGE is sent to the NIU from the INA to control several aspects of the upstream transmission. This includes stopping upstream transmission, re-enabling

transmission from a NIU or group of NIU's and rapidly changing the upstream frequency being used by a NIU or group of NIU's. To identify a group of NIU's for switching frequencies, the <MAC> TRANSMISSION CONTROL MESSAGE is sent in broadcast mode with the *Old\_Frequency* included in the message. When broadcast with the *Old\_Frequency*, the NIU shall compare its current frequency value to *Old\_Frequency*. When unequal, the NIU shall switch to the new frequency specified in the message. When equal, the NIU shall ignore the new frequency and remain on its current channel.

**Table 41: Transmission Control Message structure**

| Transmission_Control_Message(){   | Bits        | Bytes      | Bit Number / Description |
|---|-------------|------------|--------------------------|
| <b>Transmission_Control_Field</b>   | <b>8</b>    |            |                          |
| reserved  | 3           |            | 7-5:                     |
| Stop_Upstream_Transmission  | 1           |            | 4: {no, yes}             |
| Start_Upstream_Transmission   | 1           |            | 3: {no, yes}             |
| Old_Frequency_Included  | 1           |            | 2: {no, yes}             |
| Switch_Downstream_OOB_Frequency   | 1           |            | 1: {no, yes}             |
| Switch_Upstream_Frequency   | 1           |            | 0: {no, yes}             |
| <i>if (Transmission_Control_Field==<br/>Switch_Upstream_Frequency &amp;&amp;<br/>Old_Frequency_Included){</i>       |             |            |                          |
| <b>Old_Upstream_Frequency</b>   | <b>(32)</b> | <b>(4)</b> |                          |
| }   |             |            |                          |
| <i>if (Transmission_Control_Field==<br/>Switch_Upstream_Frequency){</i>   |             |            |                          |
| <b>New_Upstream_Frequency</b>   | <b>(32)</b> | <b>(4)</b> |                          |
| <b>New_Upstream_Channel_Number</b>  | <b>3</b>    | <b>1</b>   | <b>7:5</b>               |
| <b>reserved</b>   | <b>2</b>    |            | <b>4:3</b>               |
| <b>Upstream_Rate</b>  | <b>3</b>    |            | <b>2:0</b>               |
| <b>MAC_Flag_Set</b>   | <b>5</b>    | <b>1</b>   | <b>7:3</b>               |
| <b>Reserved</b>   | <b>3</b>    |            | <b>2:0</b>               |
| <b>New_Upstream_Frequency</b>   | <b>(32)</b> | <b>(4)</b> |                          |
| }   |             |            |                          |
| <i>if (Transmission_Control_Field==<br/>Switch_Downstream_OOB_Frequency &amp;&amp;<br/>Old_Frequency_Included){</i> |             |            |                          |
| <b>Old_Downstream_OOB_Frequency</b>   | <b>(32)</b> | <b>(4)</b> |                          |
| }   |             |            |                          |
| <i>if (Transmission_Control_Field==<br/>Switch_Downstream_OOB_Frequency){</i>                                       |             |            |                          |
| <b>New_Downstream_OOB_Frequency</b>   | <b>(32)</b> | <b>(4)</b> |                          |
| <b>DownStream_Type</b>  | <b>8</b>    | <b>1</b>   |                          |
| }   |             |            |                          |
| }   |             |            |                          |

54630.1 Transmission Control Field

Transmission\_Control\_Field specifies the control being asserted on the upstream channel.

#### *54630.2 Stop Upstream Transmission*

`stop_upstream_transmission` is a boolean when set indicates that the NIU should halt its upstream transmission.

#### *54630.3 Start Upstream Transmission*

`start_upstream_transmission` is a boolean when set indicates that the Network Interface Unit should resume transmission on its upstream channel. The NIU shall respond to the ranging and power calibration message regardless of the setting of the `start_upstream_transmission` bit.

#### *54630.4 Old Frequency Included*

`Old_Frequency_Included` is a boolean when set indicates that the Old Frequency value is included in the message and should be used to determine if a switch in frequency is necessary

#### *54630.5 Switch Downstream OOB Frequency*

`switch_downstream_OOB_frequency` is a boolean when set indicates that a new downstream OOB frequency is included in the message.

#### *54630.6 Switch Upstream Frequency*

`switch_upstream_frequency` is a boolean when set indicates that a new upstream frequency is included in the message. Typically, the `switch_upstream_frequency` and the `stop_upstream_transmission` are set simultaneously to allow the NIU to stop transmission and change channel. This would be followed by the <MAC> TRANSMISSION CONTROL MESSAGE with the `start_upstream_transmission` bit set.

#### *54630.7 Old Upstream Frequency*

`Old_Upstream_Frequency` is a 32-bit unsigned integer representing the frequency that should be used by the NIU to compare with its current frequency to determine if a change in channel is required.

#### *54630.8 New Upstream Frequency*

`New_Upstream_Frequency` is a 32-bit unsigned integer representing the reassigned upstream carrier center frequency. The unit of measure is Hz.

`MAC_Flag_Set` is an 5 bit field representing the MAC Flag set assigned to the connection. In the OOB downstream timing, the eight sets of flags are assigned the numbers 0..7. In the IB downstream timing, the 16 sets of flags are assigned the numbers 0..15. In the case of a 3.088 Mbit upstream channel, this parameter represents the first of two successively assigned flag sets.

`UpstreamStream_Rate` is an 3-bit enumerated bype indicating the data rate for the upstream connection. { Upstream\_256K, Upstream\_1.544M, Upstream\_3.088M, 3..7 reserved}

#### *54630.9 Old Downstream OOB Frequency*

`Old_Downstream_OOB_Frequency` is a 32-bit unsigned integer representing the frequency that should be used by the NIU to compare with its current frequency to determine if a change in channel is required.

#### *54630.10 New Downstream OOB Frequency*

`New_Downstream_OOB_Frequency` is a 32-bit unsigned integer representing the reassigned downstream OOB carrier centre frequency. The unit of measure is Hz.

DownStream\_Type is an 8-bit enumerated type indicating the modulation format for the down stream connection. { reserved, QPSK\_1.544, QPSK\_3.088, 3..255 reserved}

**Link Management Response Message (Upstream contention, fixed rate or reserved)**

The <MAC> LINK MANAGEMENT RESPONSE MESSAGE is sent by the NIU to the INA to indicate reception and processing of the previously sent Link Management Message. The format of the message is shown in table 42.

**Table 42: Link Management Acknowledge Message Format**

| Link_Management_Acknowledge() {   | Bits | Bytes | Bit Number / Description |
|-----------------------------------|------|-------|--------------------------|
| <b>Link_Management_Msg_Number</b> | 16   | 2     |                          |
| }                                 |      |       |                          |

*54630.1 Link Management Message Number*

Link\_Management\_Msg\_Number is a 16-bit unsigned integer representing the previously received link management message. The valid values for Link\_Management\_Msg\_Number are shown in table 43.

**Table 43: Link Management Message Number**

| Message Name                 | Link_Management_Msg_Number              |
|------------------------------|---|
| Transmission Control Message | Transmission Control Message Type Value |
| Reprovision Message          | Reprovision Message Type Value          |

**<MAC> Status Request Message (Downstream Singlecast)**

The STATUS REQUEST message is sent by the INA to the NIU to retrieve information about the NIU's health, connection information and error states. The INA can request either the address parameters, error information, connection parameters or physical layer parameters from the NIU. The INA can only request one parameter type at a time to a particular NIU.

**Table 44: Status Request Message structure**

| Status_Request() {          | Bits | Bytes | Bit Number / Description |
|-----------------------------|------|-------|--------------------------|
| <b>Status_Control_Field</b> | 8    | 1     |                          |
| <i>reserved</i>             | 5    |       | 3-7:                     |
| Status_Type                 | 3    |       | 0-2: {enum type}         |
| }                           |      |       |                          |

*54630.1 Status Control Field*

Status\_Control\_Field is a 3-bit enumerated type that indicates the status information the NIU should return

```
enum Status_Control_Field {Address_Params, Error_Params,
Connection_Params,Physical_Layer_Params, reserved4..7};
```

**<MAC> Status Response Message (Upstream Contention, fixed rate or reserved)**

The <MAC> STATUS RESPONSE MESSAGE is sent by the NIU in response to the <MAC> STATUS REQUEST MESSAGE issued by the INA. The contents of the information provided in this message will vary depending on the request made by the INA and the state of the NIU. The message must be dissociated into separate messages if the resulting length of the message exceeds 40 bytes.

**Table 45: Status Response Message Structure**

| Status_Response(){   | Bits  | Bytes | Bit Number/Description |
|--|-------|-------|------------------------|
| <b>NIU_Status</b>  | 32    | 4     |                        |
| <b>Response_Fields_Included</b>  | 8     | 1     |                        |
| reserved   | 4     |       | 4-7:                   |
| Address_Params_Included  | 1     |       | 3: {no, yes}           |
| Error_Information_Included   | 1     |       | 2: {no, yes}           |
| Connection_Params_Included   | 1     |       | 1: {no, yes}           |
| Physical_Layer_Params_Included   | 1     |       | 0: {no, yes}           |
| <i>if (Response_Fields_Included == Address_Params_Included){</i>         |       |       |                        |
| <b>NSAP_Address</b>  | (160) | (20)  |                        |
| <b>MAC_Address</b>   | (48)  | (6)   |                        |
| <i>}</i>   |       |       |                        |
| <i>if (Response_Fields_Included == Error_Information_Included){</i>      |       |       |                        |
| <b>Number_Error_Codes_Included</b>                                       | (8)   | (1)   |                        |
| <i>for(i=0; i&lt;Number_Error_Codes_Included; i++){</i>                  |       |       |                        |
| <b>Error_Param_code</b>  | (8)   | (1)   |                        |
| <b>Error_Param_Value</b>   | (16)  | (2)   |                        |
| <i>}</i>   |       |       |                        |
| <i>}</i>   |       |       |                        |
| <i>if (Response_Fields_Included == Connection_Params_Included) {</i>     |       |       |                        |
| <b>Number_of_Connections</b>   | (8)   | (1)   |                        |
| <i>for(i=0; i&lt;Number_of_Connections; i++){</i>                        |       |       |                        |
| <b>Connection_ID</b>   | (32)  | (4)   |                        |
| <i>}</i>   |       |       |                        |
| <i>if (Response_Fields_Included == Physical_Layer_Params_Included) {</i> |       |       |                        |
| <b>Power_Control_Setting</b>   | (8)   | (1)   |                        |
| <b>Time_Offset_Value</b>   | (32)  | (4)   |                        |
| <b>Upstream_Frequency</b>  | (32)  | (4)   |                        |
| <b>Downstream_Frequency</b>  | (32)  | (4)   |                        |
| <i>}</i>   |       |       |                        |
| <i>}</i>   |       |       |                        |

**54630.1 NIU Status**

NIU\_Status is a 32-bit unsigned integer that indicates the current state of the NIU.

```

NIU_Status { Calibration_Operation_Complete,
Default_Connection_Established,
Network_Address_Registered,
,reserved};

```

#### 54630.2 Response Fields Included

Response\_Fields\_Included is an 8-bit unsigned integer that indicates what parameters are contained in the upstream status response.

#### 54630.3 NSAP Address

NSAP\_Address is a 20 byte address assigned to the NIU.

#### 54630.4 MAC Address

MAC\_Address is a 6 byte address assigned to the NIU.

#### 54630.5 Number of Error Codes Included

Number\_Error\_Codes\_Included is an 8-bit unsigned integer that indicates the number of error codes are contained in the response.

#### 54630.6 Error Parameter Code

Error\_Parameter\_Code is a 8-bit unsigned integers representing the type of error reported by the NIU.

**Table 46: Error Parameter Code**

| Error Parameter Code Name          | Error Parameter Code |
|------------------------------------|----------------------|
| Framing_Bit_Error_Count            | 0x00                 |
| Slot_Configuration_CRC_Error_Count | 0x01                 |
| Reed_Solomon_Error_Count           | 0x02                 |
| ATM_Packet_Loss_Count              | 0x03                 |

#### 54630.7 Error Parameter Value

Error\_Parameter\_Value is an 16-bit unsigned integers representing error counts detected by the NIU.

#### 54630.8 Number of Connections

Number\_of\_Connections is an 8-bit unsigned integer that indicates the number of connections that are specified in the response. Specifically, if the number of connections is too large to have a MAC message with less than 40 bytes, it is possible to send separate messages with only the number of connections indicated in each message.

#### 54630.9 ConnectionID

Connection\_ID is a 32-bit unsigned integer representing the global connection Identifier used by the NIU for this connection.

#### 54630.10 Power Control Setting

Power\_Control\_Setting is a 8-bit unsigned integer representing the absolute power attenuation that the NIU is using for upstream transmission

#### *54630.11 Time Offset Value*

`Time_Offset_Value` is a 16-bit short integer representing a relative offset of the upstream transmission timing. A negative value indicates an adjustment forward in time. A positive value indicates an adjustment back in time. The unit of measure is 100 nsec.

#### *54630.12 Upstream Frequency*

`Upstream_Frequency` is a 32-bit unsigned integer representing the channel assigned to the connection. The unit of measure is in Hz.

#### *54630.13 Downstream Frequency*

`Downstream_Frequency` is a 32-bit unsigned integer representing the Frequency where the connection resides. The unit of measure is in Hz.